

TrueBlueSheds

Modern Sheds Built Aussie Tough

Framing Components



Leanto rafter to double-column assembly without drop

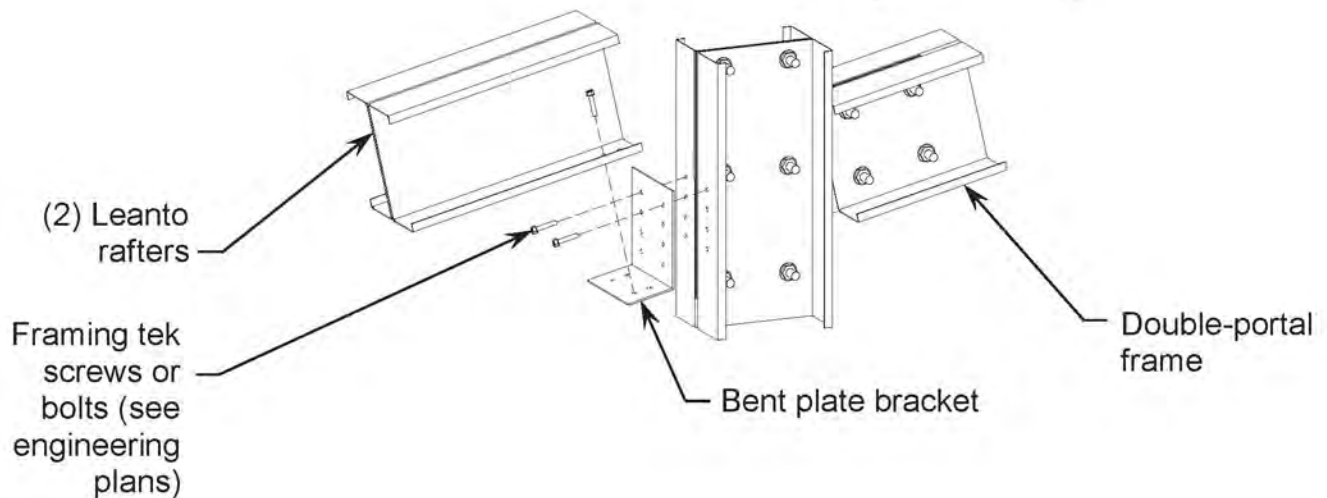



Appendix B – Framing Component Installation

Last updated 12/3/2020

Apex Brace Installation

Refer to apex connection detail on the engineering plans for the location of the apex brace. Refer to the member and material schedule on the engineering plans for size, gauge and type of apex brace and number of bolts or screws necessary to install the apex brace.

To install an apex brace you must first cope the flanges of the apex brace CEE section. In some building configurations, punches will be made on the flanges of the apex brace to indicate the sections to be coped. If your apex braces come with these punches, the flanges can be coped up to and including the punch. If punches are not present, you will have to calculate the exact locations to cope the flanges, using the information found on the engineering plans.

If you are installing the apex braces using framing bolts, holes will have either been factory punched or need to be pre-drilled onsite before installation, per engineering plans.

Once the CEE section is coped, you will attach it to the rafters with bolts or screws, which are specified on the member and material schedule on the engineering plans.

Note that if your building has a gambrel-style roof pitch, each portal frame will have three separate apex brace assemblies. See apex connection detail on the engineering plans for further instructions.

Please see the illustrations below and on the next page as a reference for attaching the apex brace to the rafters. Note that the exact location, number and type of the bolts or screws are specified on the engineering plans but are not represented on the illustrations.

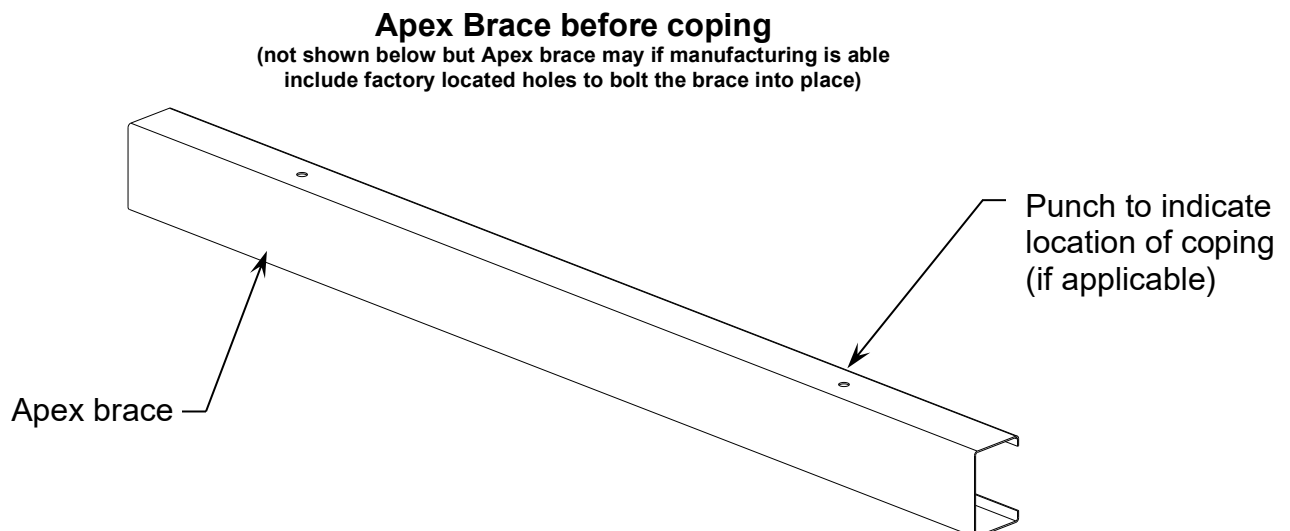



Single-rafter apex brace assembly

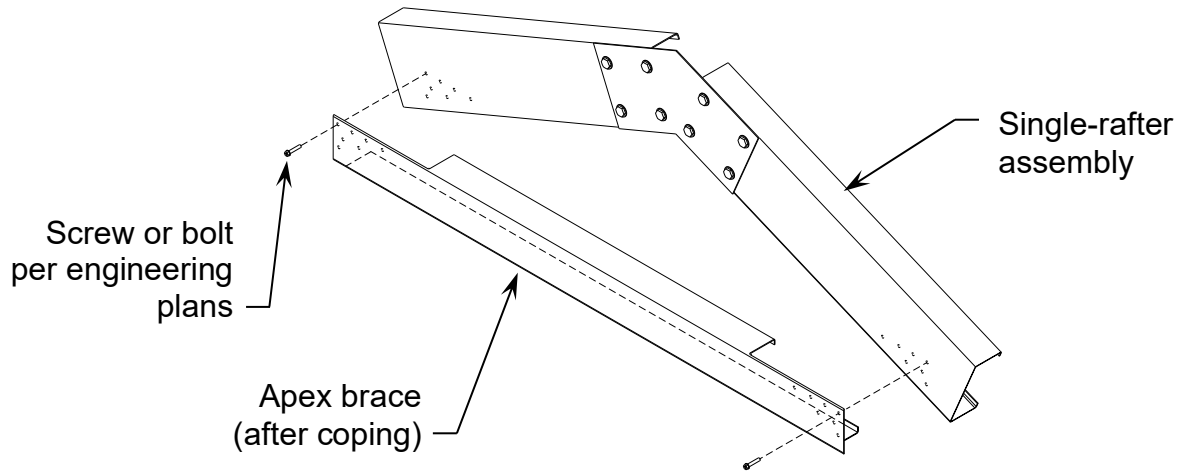

Double-rafter apex brace assembly

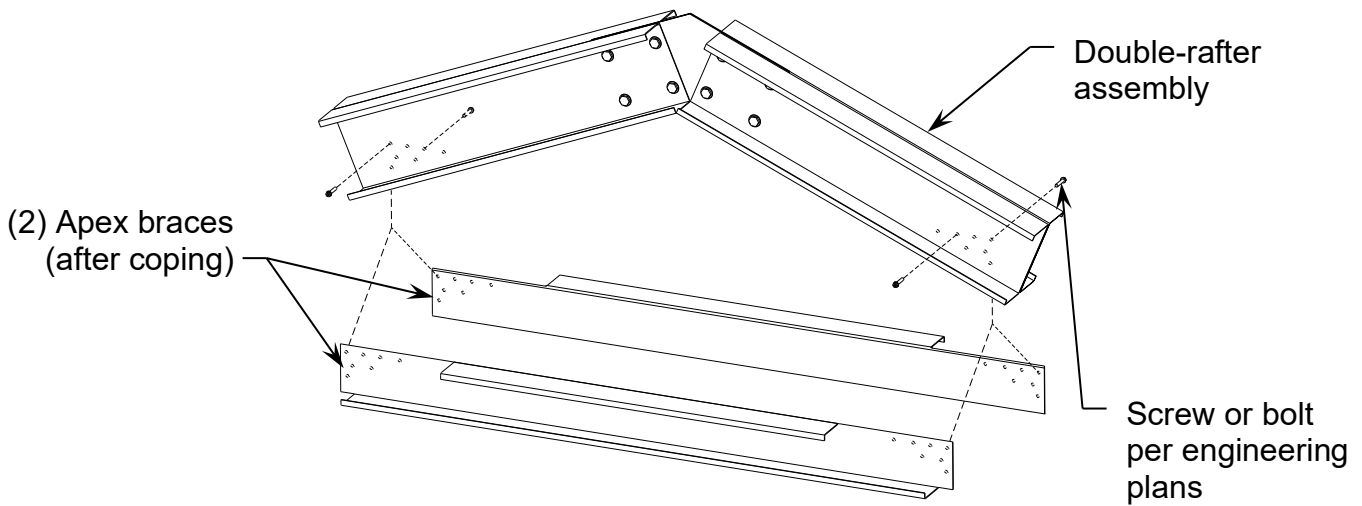



Apex Bracket Installation

Connect rafters to apex bracket with bolts. Please see engineering plans for number and type of apex brackets and see the member and material schedule on the engineering plans for number and type of rafters.

Note that if your building has a gambrel-style roof pitch, each portal frame will have three rafter-to-apex bracket connections, one at the roof apex and two connecting the rafters to the lower rafters. See apex connection detail on the engineering plans for further instructions. Please see the illustrations below for reference.

Single-rafter to apex bracket assembly

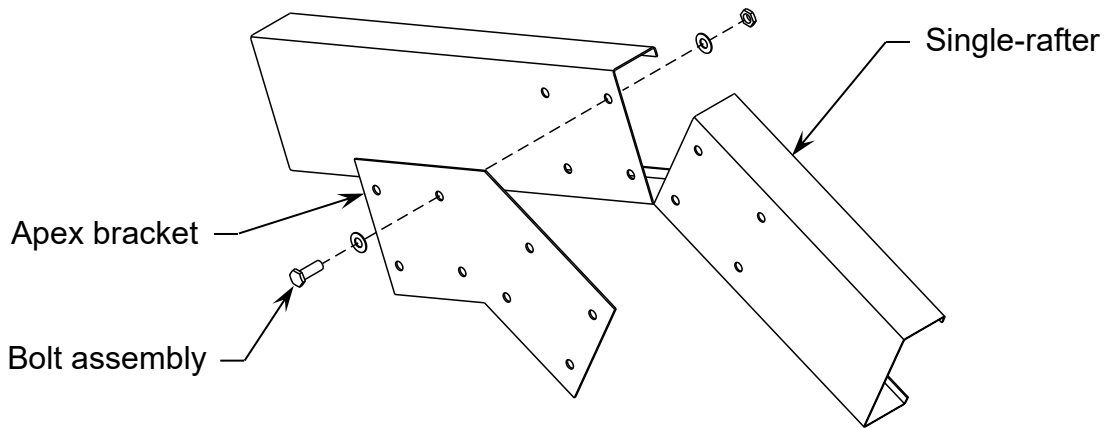

Double-rafter to apex bracket assembly

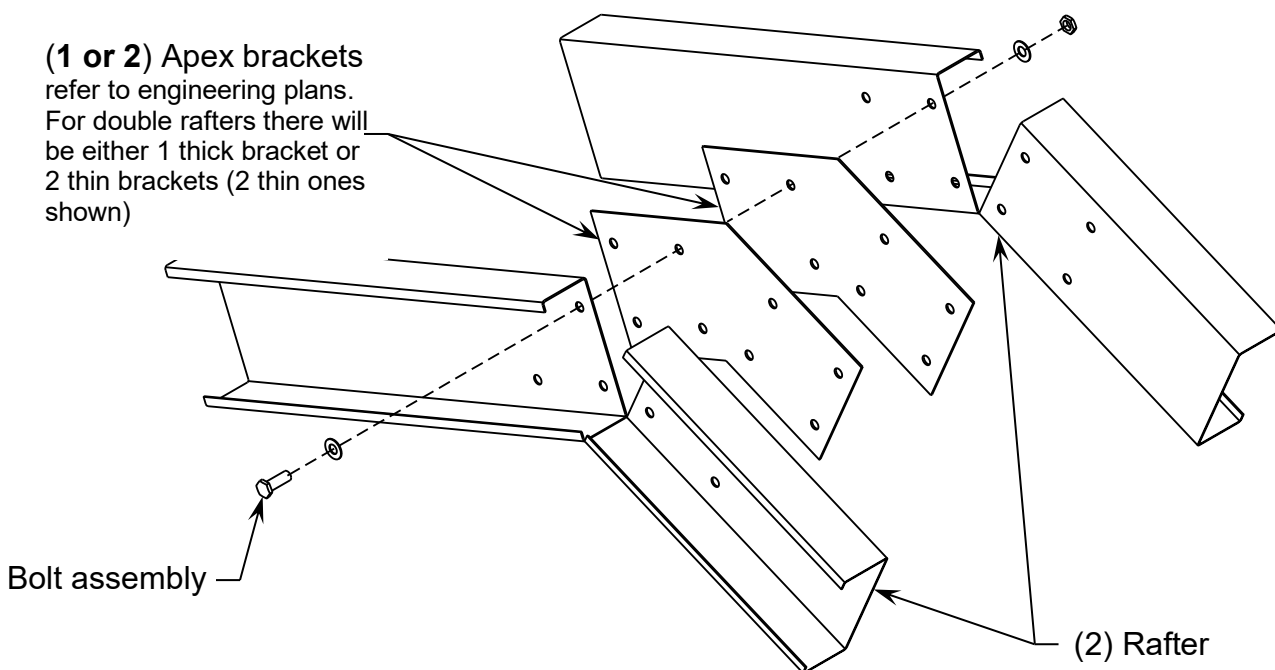



Base Angle Installation

If you have base angle on your building, it will be on your building order and will be indicated on the foundation plan of the engineering plans.

Base angle is installed to the slab using the fastening anchors and spacings as shown on the engineering plans. If not factory produced then there may be a requirement to drill holes in the base angle to take the fastening anchors.

Before continuing, roll mastic can be applied to the bottom of the base angle. This will fully seal the space between the base angle on the concrete slab and also hold base angle in place during the rest of the installation process.

When ready, line up edge of base angle to edge of slab. Drill a hole in the concrete $\frac{1}{4}$ " in size and at least 1" deep through the already-created holes in the base angle. Clear the hole of any concrete dust. Then use a sledgehammer to install the fastening anchors, force them into the drilled hole.

Note that the base angle will be installed around the entire slab, except when a column or door jamb impedes the installation of the base angle. Please see the foundation plan on the engineering plans for fastening anchors spacing and locations.

Please see the illustration below as a reference on the installation of the base angle. Also refer to the foundation plan on the engineering plans for exact requirements on base angle installation.

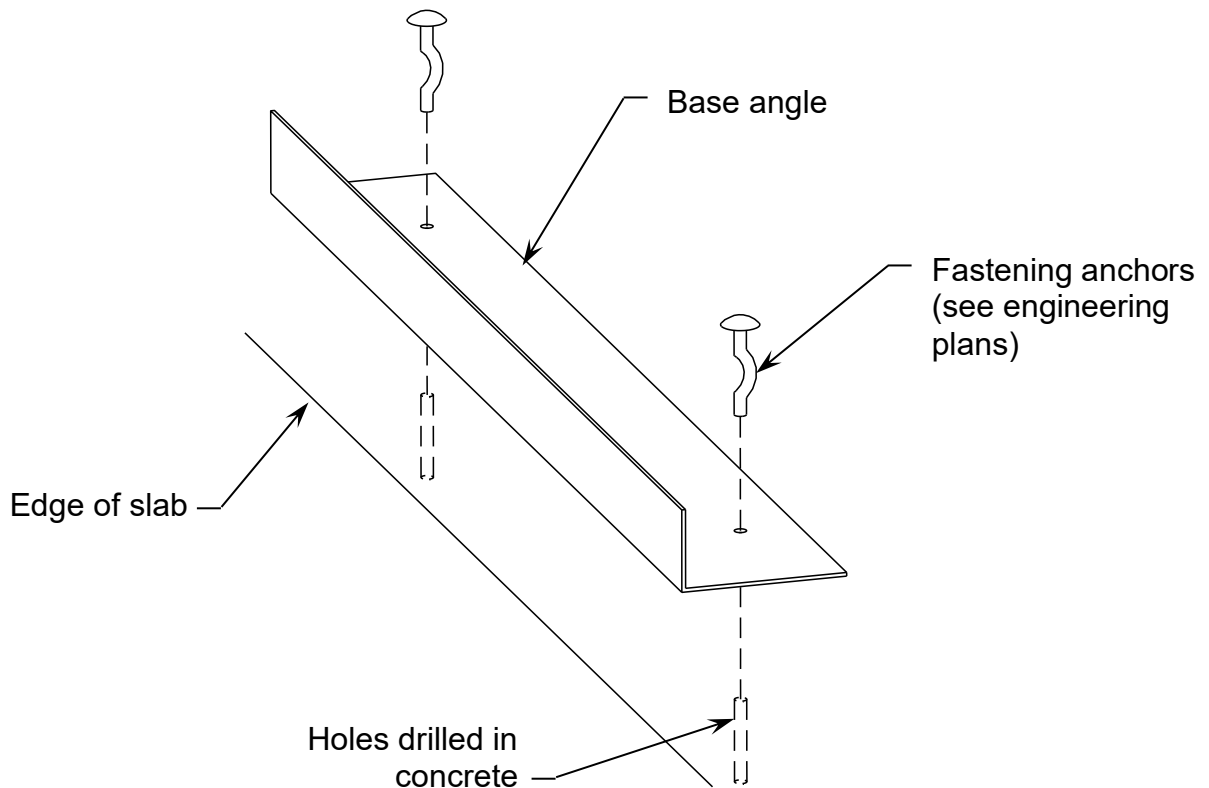



Column Base Installation

Columns are attached to the foundation of your building using column anchor brackets and concrete anchors. These concrete anchors can require specific drill bits, or special inspection during installation. Please refer to the member and materials schedule of the engineering plans for these requirements before continuing.

After ascertaining the exact location of the anchor bolts, drill the anchor bolt holes, using a rotary drill to drill holes in the concrete slab. Make sure that drilled hole is deep enough for concrete anchor to fit in the hole snugly. Once the hole is drilled, you must clear it of any remaining concrete dust by using compressed air. If no water is present in the hole, using an air puffer to clean the hole of dust will suffice.

Next, attach column anchor brackets to the bottom of the column using bolt assembly, tightening the bolt assemblies by hand. For exact information on the column anchor bracket and bolt type, see engineering plans.

Lastly, stand up column and install your concrete anchor through column anchor bracket to concrete slab. When complete tighten bolt assemblies with impact wrench. Please see the illustrations below as a reference for attaching the columns to the foundation.

Single-column base connection

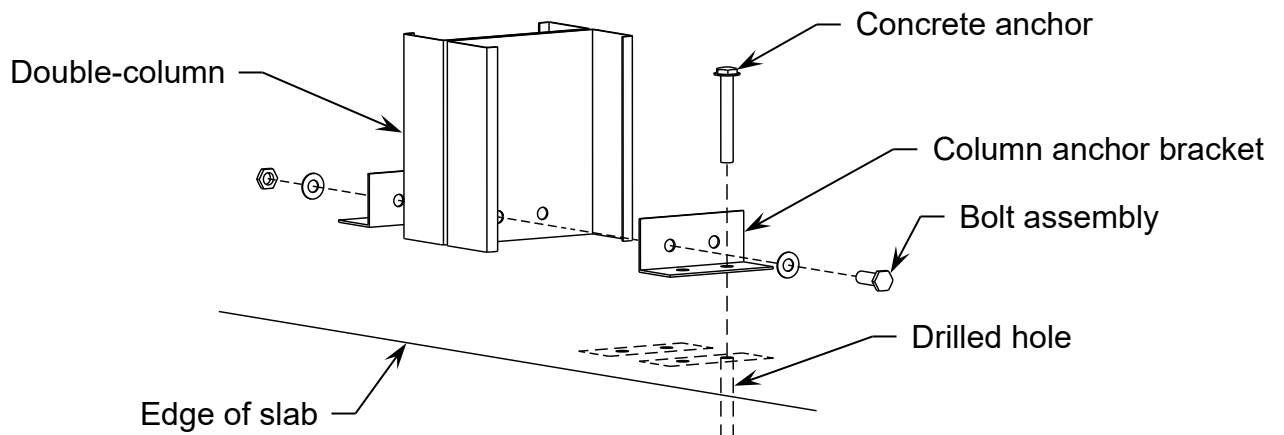
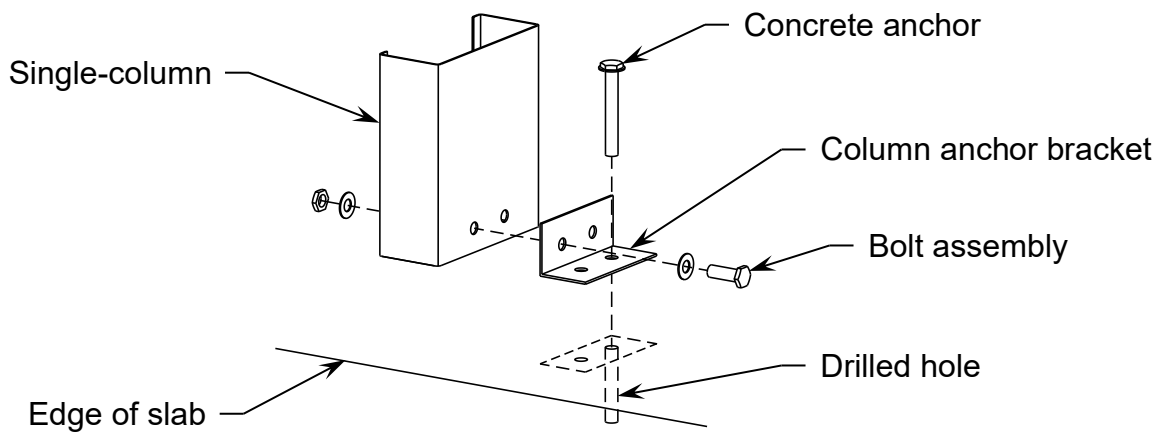



Corner and Rake Angle Installation

If corner and rake angle is provided in your building kit, it will be installed on the ends of all girts and purlins and will be attached using a pan head self-drilling screws. When installing at the ends of wall girts, corner angle should run from the edge of the slab to the eave of the building. When installing at the ends of purlins, rake angle should run from the eave to the apex of the building. Please see the illustration below as a reference for installing corner and rake angle.

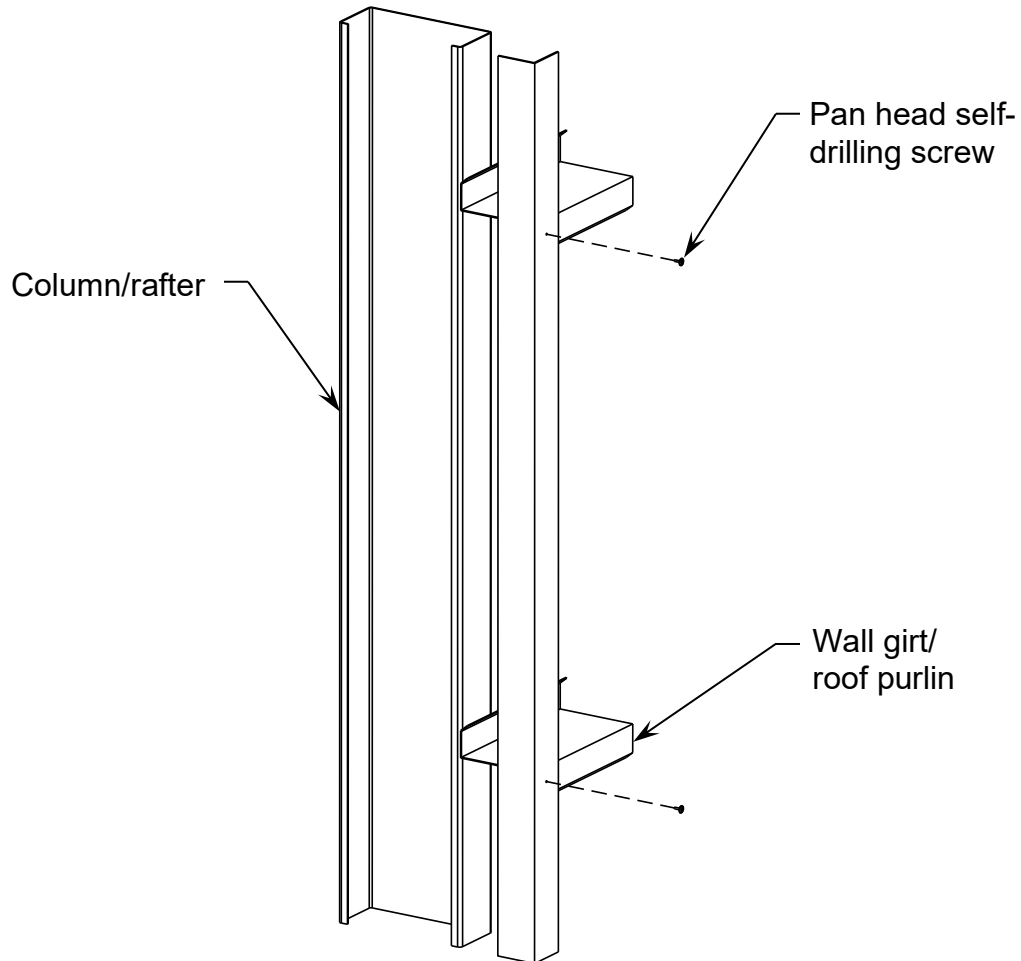



Corner Column Stiffener Installation

In some cases, you will need to install a corner column stiffener (which is comprised of a CEE section) at specific corner columns. This will be indicated on your engineering plans. You will attach the stiffener to the corner column using framing tek screws or bolts. Note that corner column stiffener will run from top of column anchor bracket to bottom of the haunch bracket.

In some cases, other components, such as a mezzanine floor bracket, will need to be installed to a column that requires a corner column stiffener. In this case, both components will need to be installed, first installing the mezzanine bracket, and then installing the corner column stiffener to the column, over the mezzanine floor bracket. Note that corner column stiffeners will always need to run continuously from the column anchor bracket to the haunch bracket, regardless of other components to be installed.

The *only* case where corner column stiffeners should be coped or cut in any way is when the bolts at a mezzanine bracket on the corner column are 4" apart horizontally, and the corner column stiffener must fit between them. In this case, move the stiffener slightly off the center of the column so that the web of the stiffener is between the mezzanine bracket bolts. Then cope off the flange and stiffener lip of the corner column stiffener in two locations, where the bracket bolts would interfere with the corner column stiffener.

Please see the engineering plans for exact information on size, location and installation of corner column stiffener. See the illustrations below as an example of how to install the corner column stiffeners.

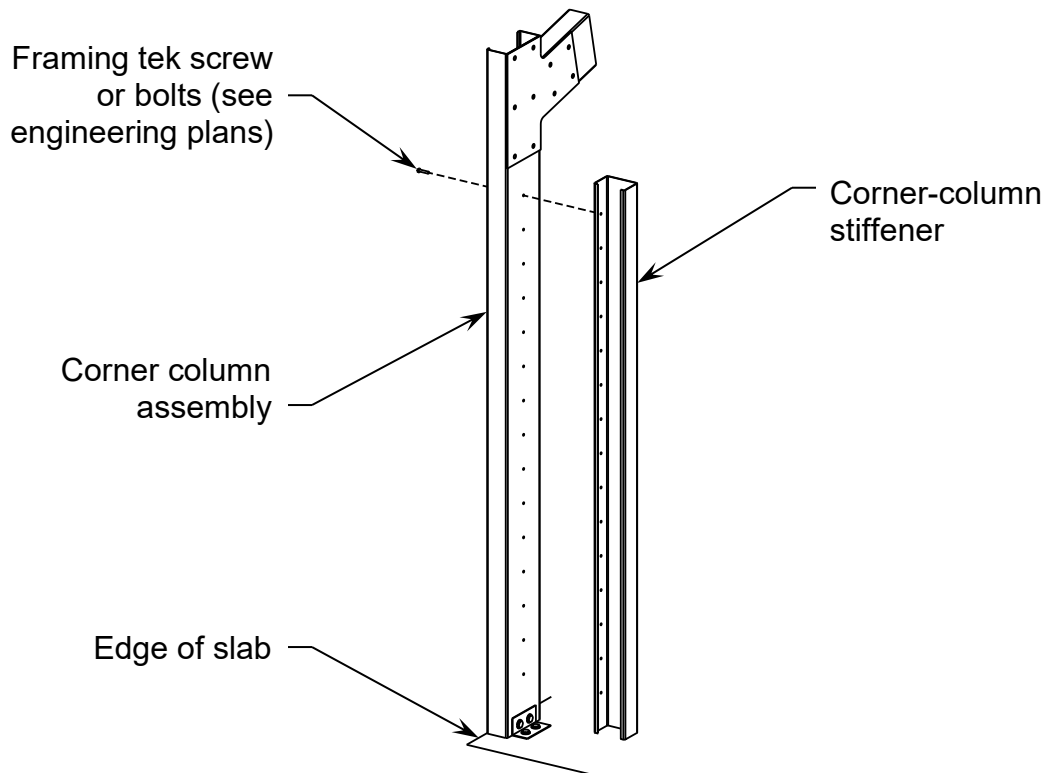



Eave Purlin Bracket Installation

Connect eave purlin bracket to column using framing tek screws or bolts. Please see the illustrations below as a reference for attaching the eave purlin bracket to the columns. Check your engineering plans for eave purlin bracket method to use.

Method 1 – Standard Bracket

For the standard eave purlin bracket assembly, the framing tek screws should be as far apart from each other as possible.

Standard eave purlin bracket to single-column assembly

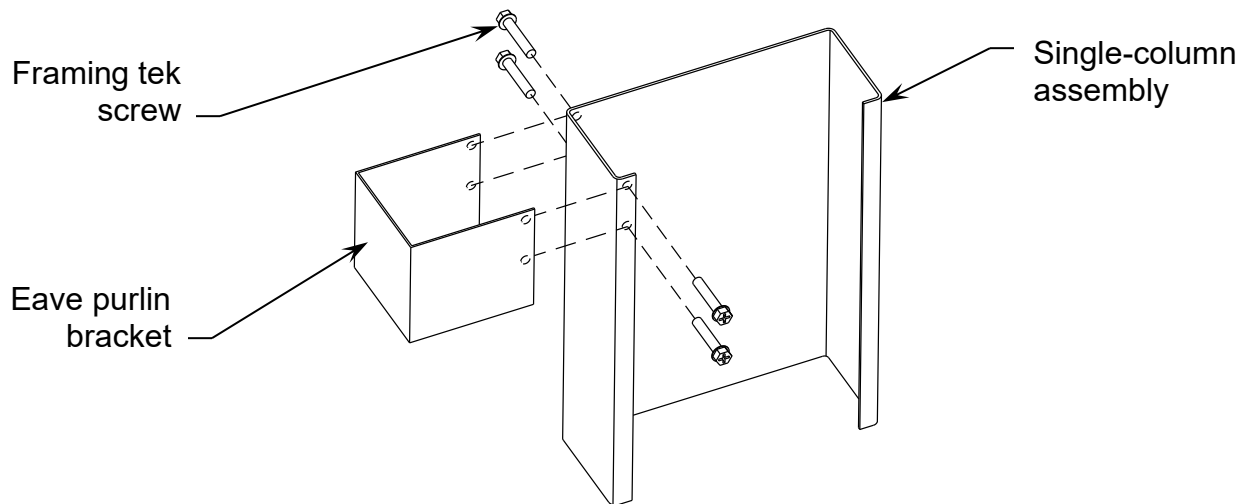

Standard eave purlin bracket to double-column assembly

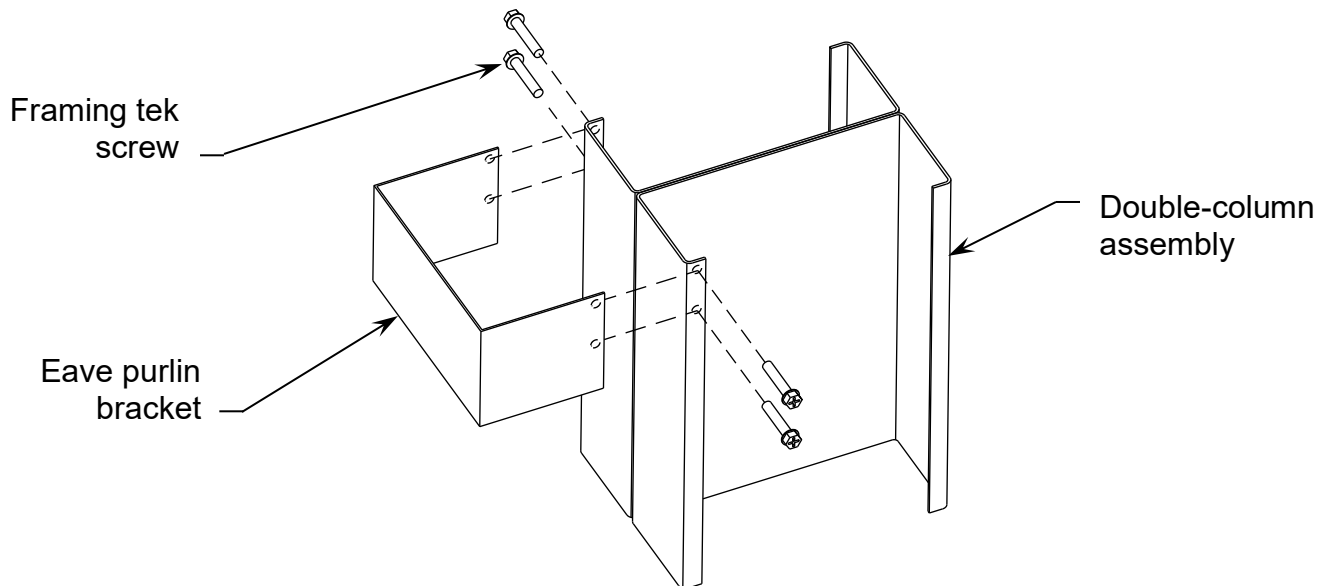



Exact location of bracket will vary per building. The eave purlin bracket should be installed so that when the eave purlin is attached to the eave purlin bracket, the bottom lip of the eave purlin will align with the bottom of the eave purlin bracket. Thus, the distance between the top of the eave purlin bracket and the top of column varies per building. This distance is illustrated below and can be found in the table below. Also note that the eave purlin bracket will need to be installed so that the bracket will line up with the slab edge. Thus, the edge of the eave purlin will not always line up with the edge of the stiffener lip of the column CEE. This distance will need to be determined at time of construction.

Please see below for an illustration of how the location of the eave purlin bracket can vary. The eave purlin bracket offset distance will be listed on your engineering plans.

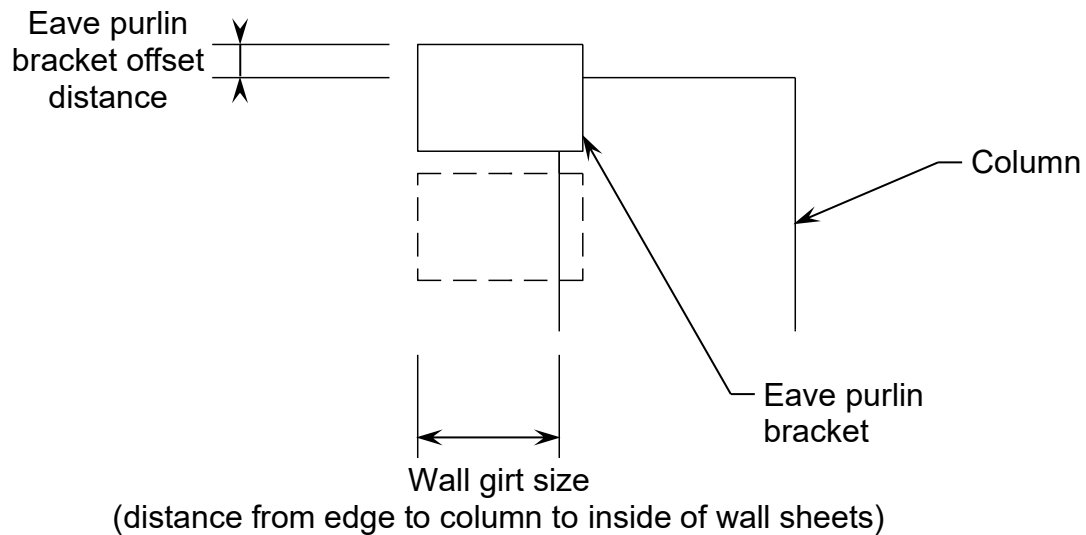

Method 2 – ZEE Eave Purlin Bracket

A ZEE Eave Purlin Bracket will be installed on all walls with girts that are 8” or larger on double-column assemblies. Simply install a short section of ZEE (exact length and bracket location will be listed on your engineering plans) to the front of the column.

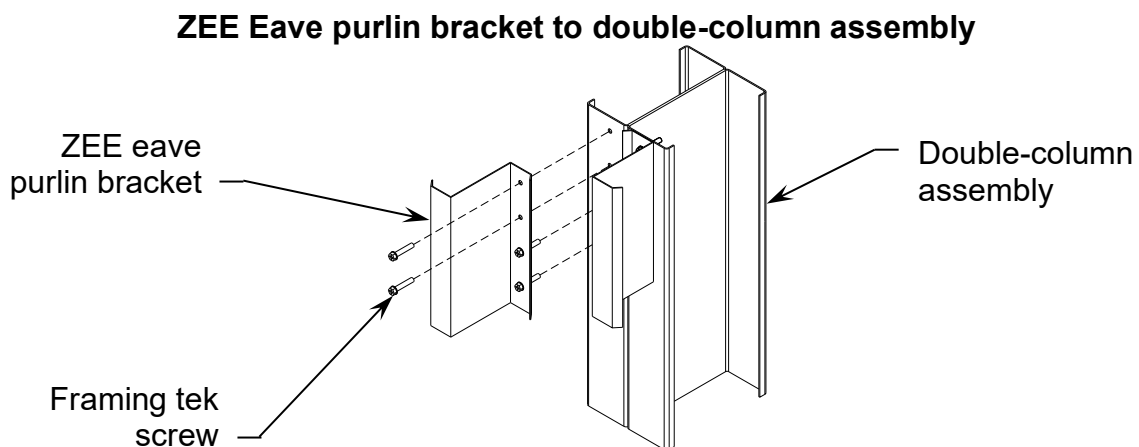



Method 3 – CEE Eave Purlin Bracket

A CEE Eave Purlin Bracket will be installed to the outside column flange. Install a short section of CEE to the outside flange of the column using framing tek screws, or bolts (refer to the engineering plans for the location, size, and fastening type).

CEE Eave purlin bracket to single column

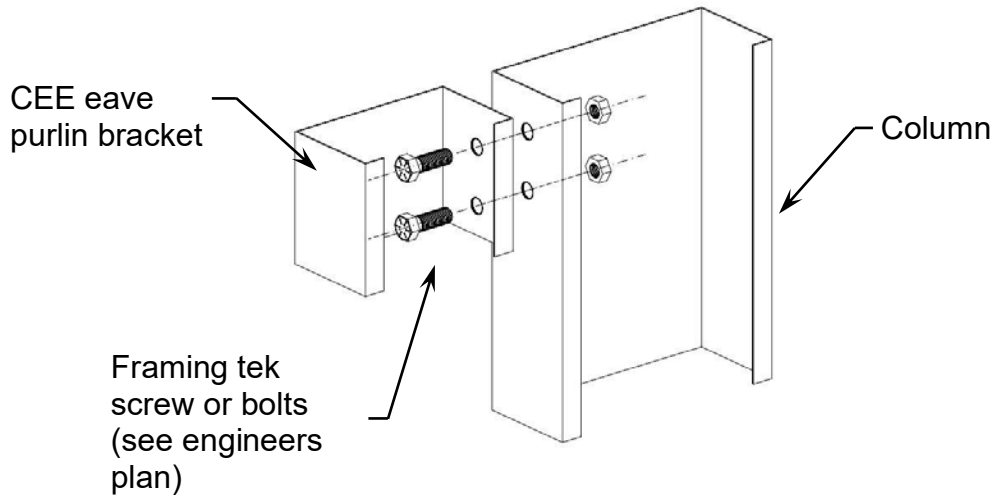

CEE Eave purlin bracket to double-column assembly

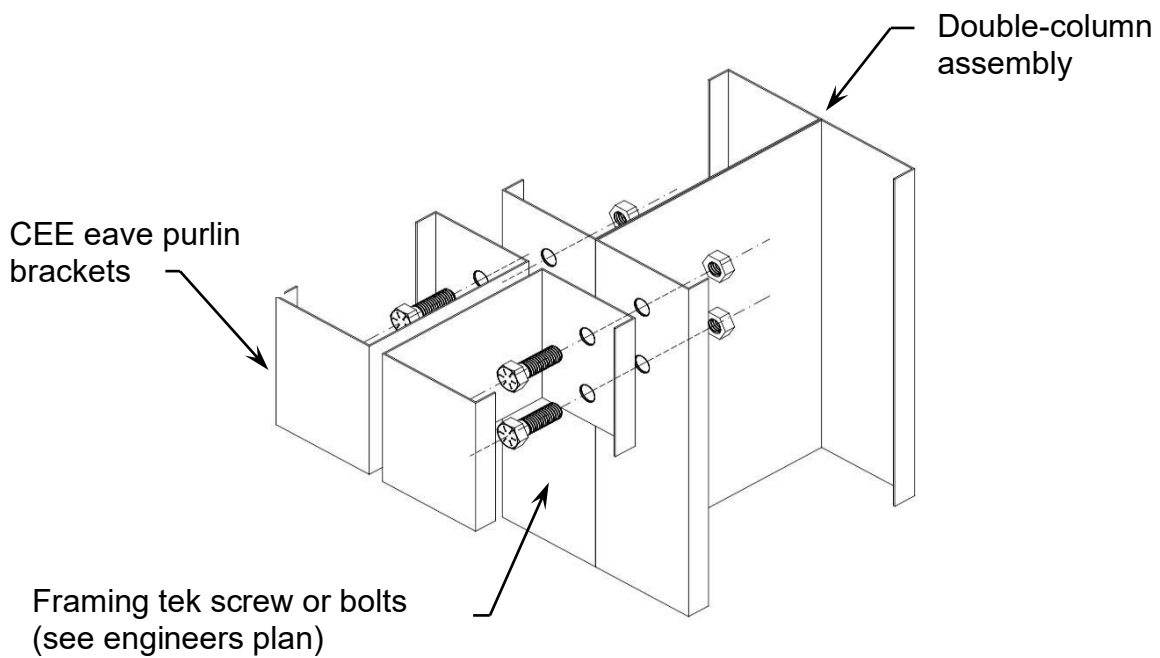



Eave Purlin Installation

Connect eave purlin to eave purlin bracket using framing tek screws. Note that the exact location of the eave purlin bracket varies. For specifications on how eave purlin bracket must be placed, see “Eave Purlin Bracket Installation” section above. Do not install eave purlin until all conditions are met.

To install the eave purlin bracket, place the eave purlin so that the bottom stiffener lip is pushed up to touch the bottom of the eave purlin bracket and the front of the eave purlin is flush with the front of the eave purlin bracket. Then, install two framing tek screws from each eave purlin into the eave purlin bracket. Note that the eave purlin can be either a CEE Section or an Eave Strut.

Note that when you install the eave purlin, when it connects to the eave purlin bracket on the corner column, the edge of the eave purlin must line up with the edge of the eave purlin bracket. When installing eave purlin on an interior sidewall column, eave purlin will fall in center of eave purlin bracket. Also, once the eave purlin is installed, the top of the eave purlin should align with the eave of the building.

Please see the illustrations below and on the following page as a reference for attaching the eave purlin to the eave purlin bracket.

Eave purlin to single-column assembly

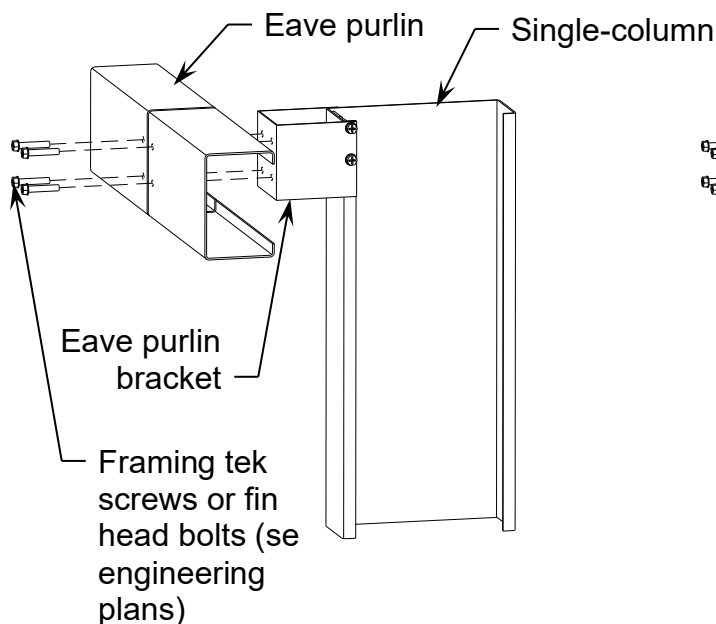

Eave purlin to double-column assembly

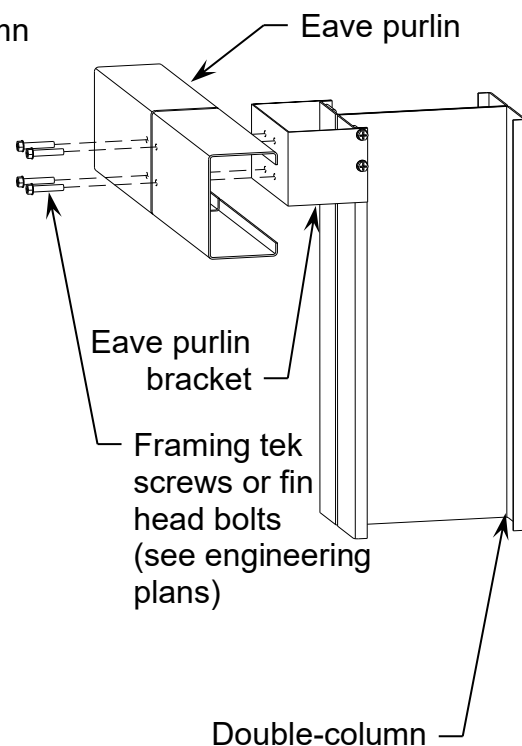



Eave purlin to corner-column assembly

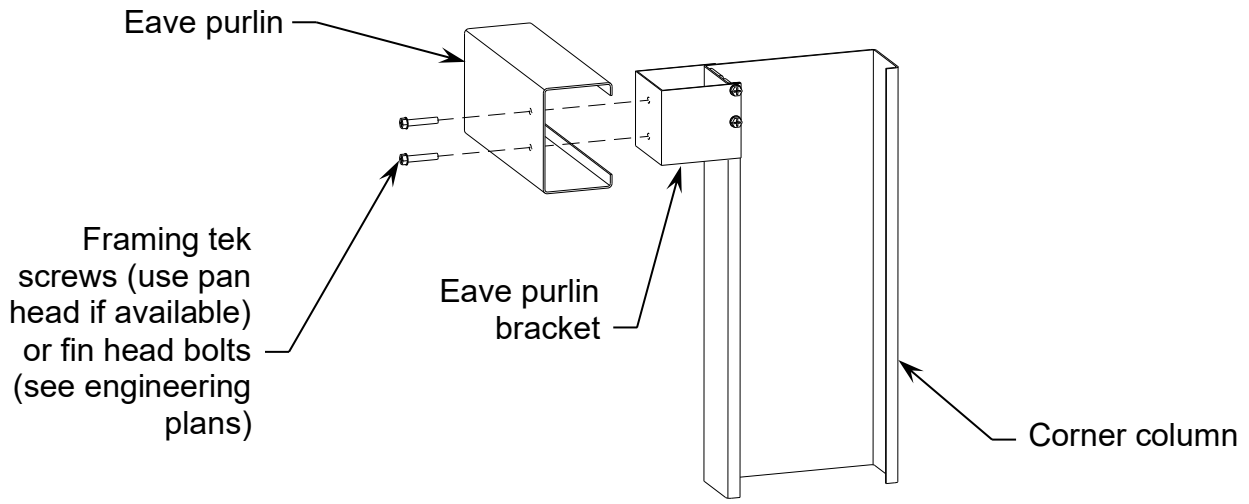



Endwall Column Installation

For installation of base of endwall columns, see “Column Base Installation” section earlier in appendix

After installing base of endwall column, top of endwall column will need to be attached to the rafter. Before securing top of endwall column, ensure that column is plumb.

When installing endwall columns, there are many variations that can occur. Before proceeding, ascertain whether endwall columns are single or double. This information can be found in the member and material schedule on the engineering plans.

The endwall column will attach directly to the rafter and will be installed using framing tek screws or bolts, as specified on engineering plans.

Because of this, if your building has 6” or larger endwall girts, the corner columns and endwall rafter in the endwall will be set in from the edge of the slab, so that the back of the endwall portal assembly will align with the back of the endwall girts. Please see the engineering plans for more information if you have endwall girts that are 6” or larger.

If an endwall column is being installed in the middle of the endwall, it will need to attach to the apex of the rafters. In this case, some of the bolts that connect the rafters and apex bracket together could impede the installation of the endwall column. If this is the case, it is permissible to remove two of the bolts of this connection, but only the bolts that are to the inside and toward the bottom of the rafter. This is shown in the illustrations on the following pages.

Please see the illustrations on the following pages as a reference for attaching the endwall columns to the rafters. For exact information on attaching the top of endwall columns to the rafter, please see the engineering plans.



Single-endwall column to rafter assembly

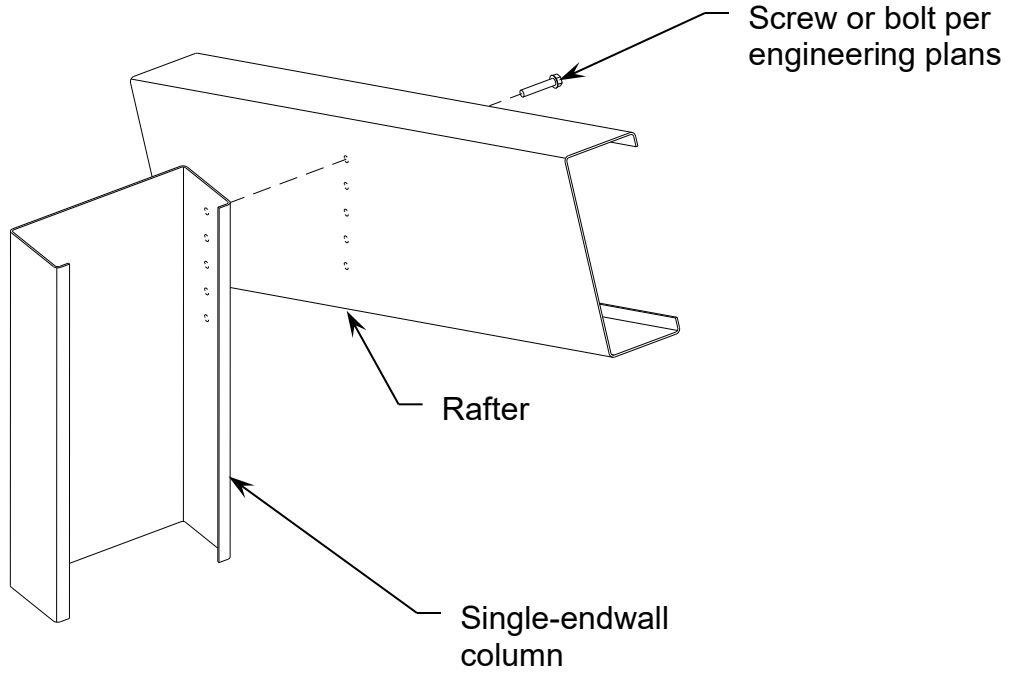

Double-endwall column to rafter assembly

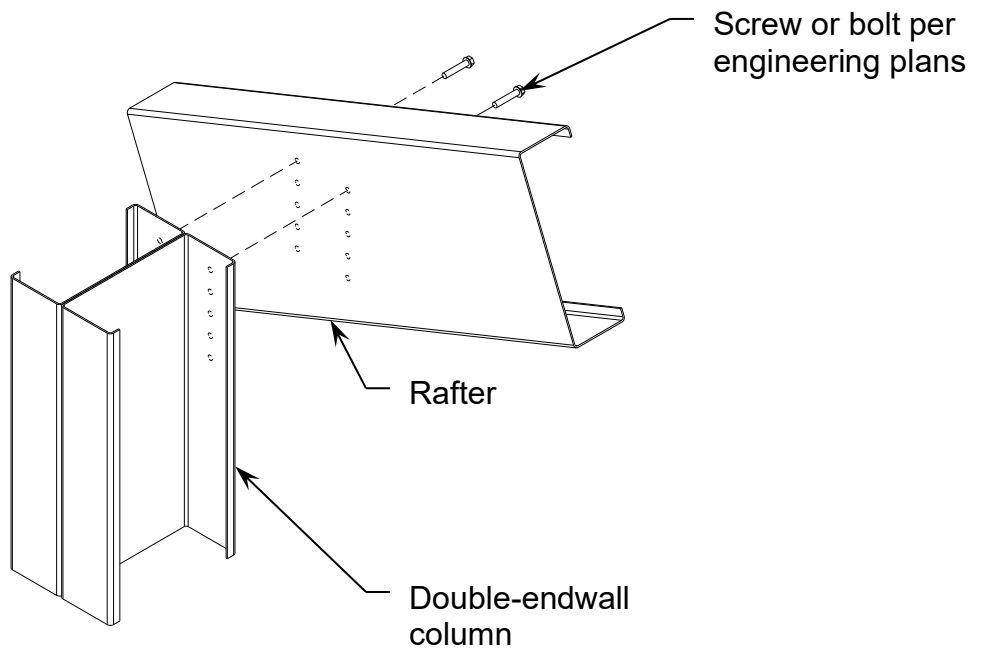



**Single-endwall column to rafter assembly
installed at apex**

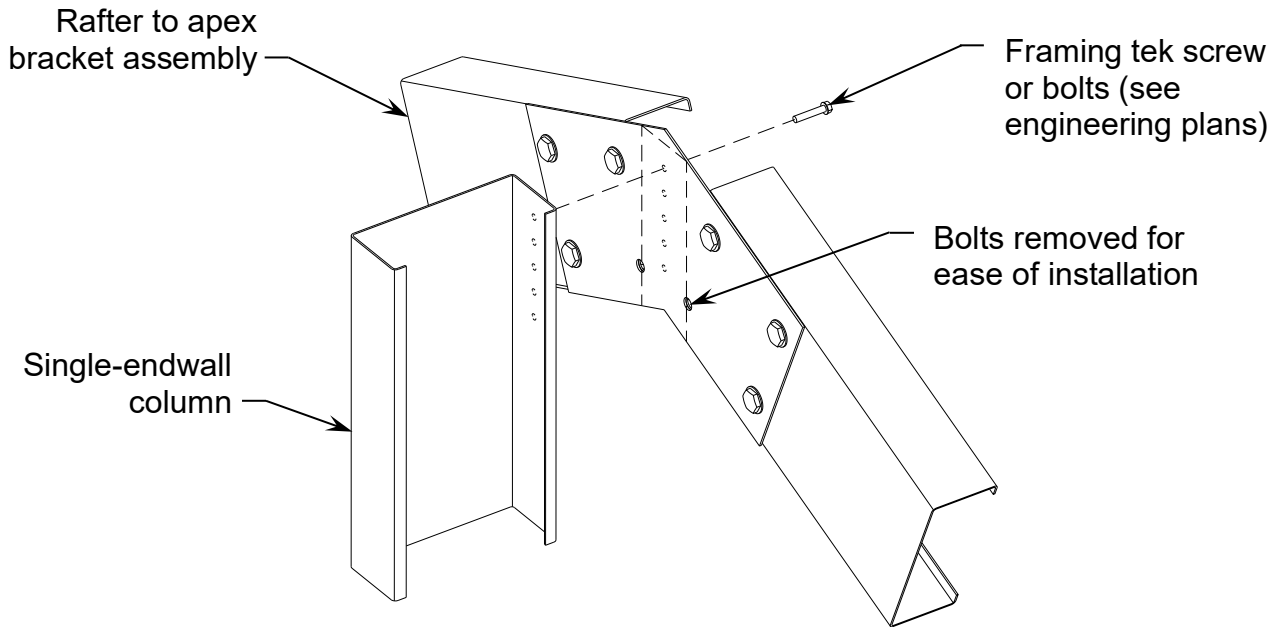

**Double-endwall column to rafter assembly
installed at apex**

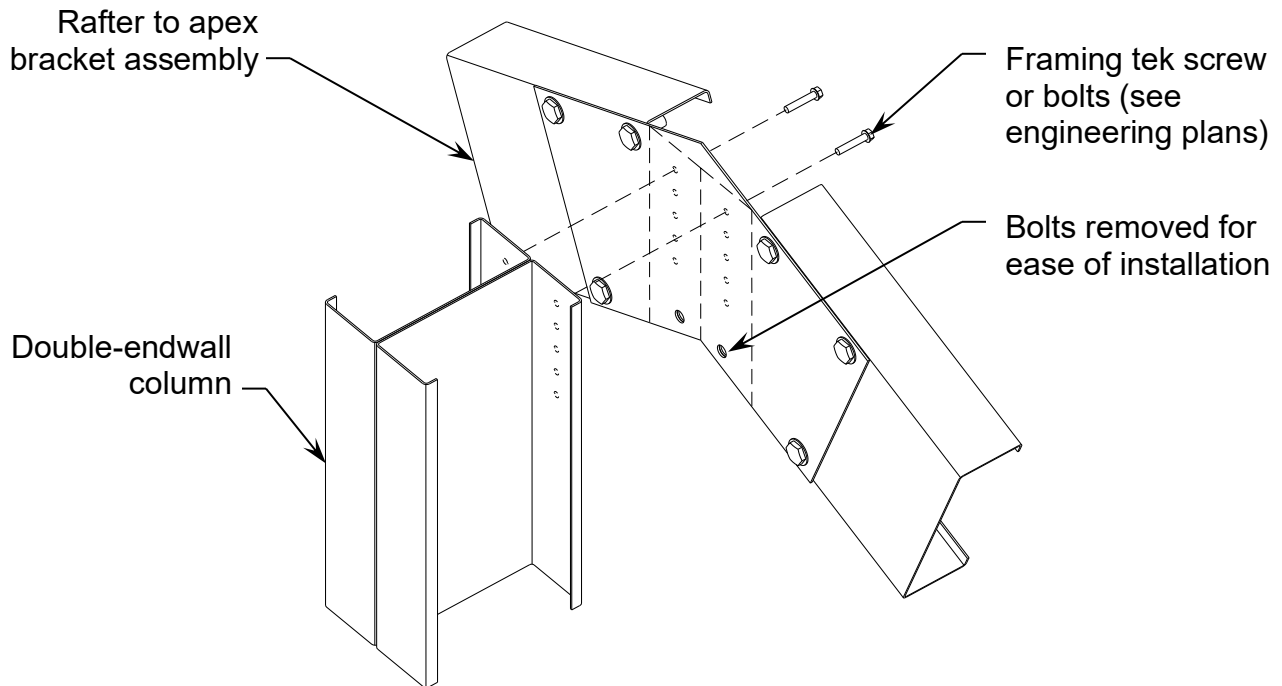



Flybracing Installation

After installing columns and rafters, you may have to install flybracing. This is detailed and can be found on the engineering plans.

Flybracing is installed by attaching strapping (the exact type as used for x-bracing) to both the frame (either column or rafter) and the girt or purlin using framing tek screws or bolts.

In some instances, flybracing can only be installed on one side of the girt/purlin. When this is the case, attach from the frame to the girt using a two legged member with a minimum of 1.5" legs. It is best to fashion this out of excess material since this item will not be found in your building order. Please see the details on the engineering plans for exact information on installing flybracing using this alternate method.

Please see the illustrations below as a reference for installing flybracing.

Flybrace installation at single-frame

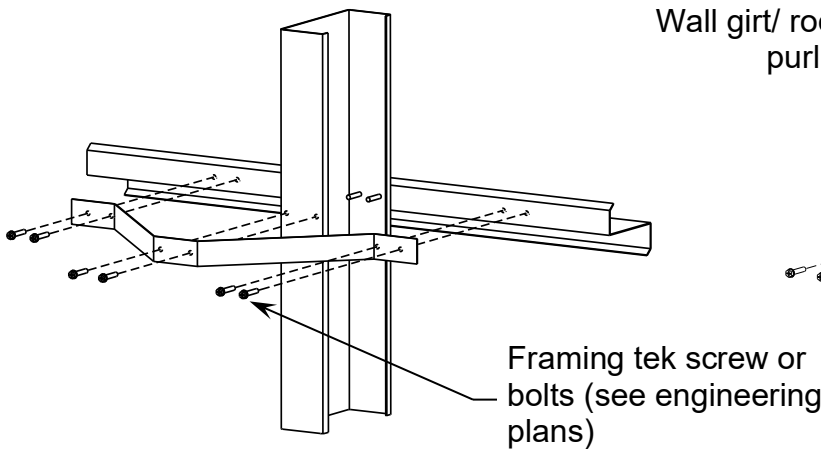

Alternate flybrace installation at single-frame

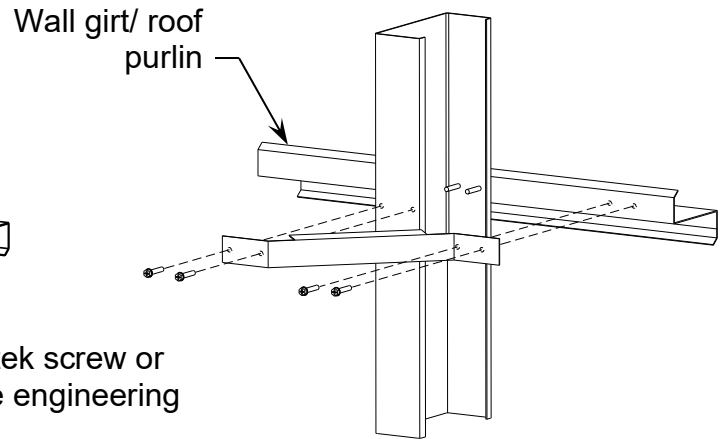

Flybrace installation at double-frame

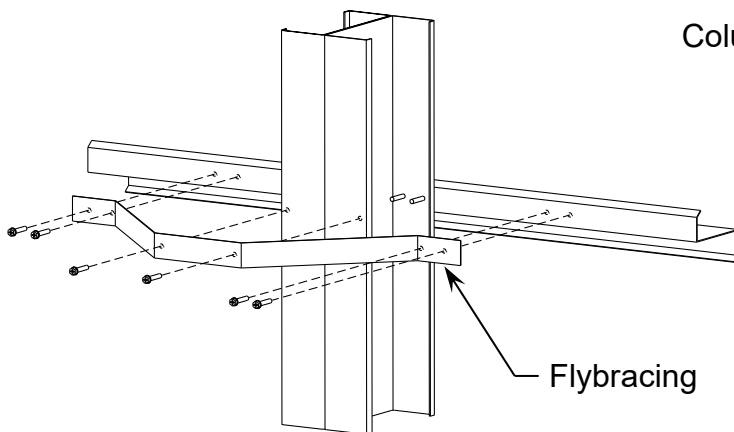

Alternate flybrace installation at double-frame

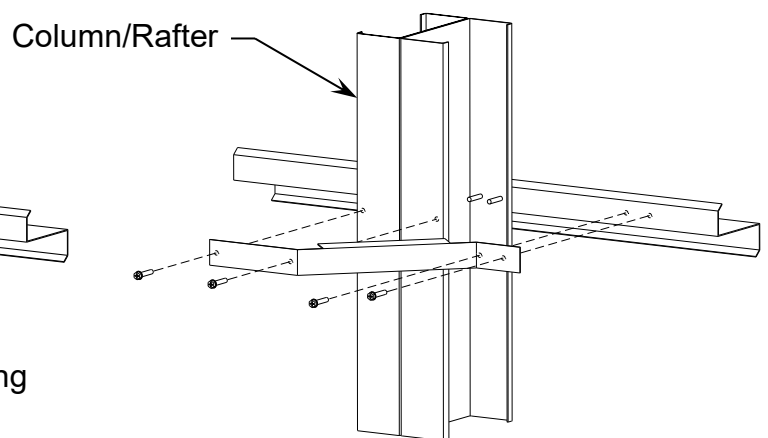



Girt (Sidewall and Endwall) Installation

Girts are installed on the sidewall and endwalls of your building and are connected to the sidewall and endwall columns. Each wall girt is connected from one column to the adjacent column using framing tek screws or bolts (see engineers plan). When overlapping girts, they *must* overlap at a sidewall or endwall column.

Installation of girts is different for those bays that have doors and windows. Please see Appendix A (Door and Window Installation section) for more information on this aspect of girt installation.

Note that for some buildings, LGSIs will be used to make up the wall girts. Please check your engineering plans or order to see if an LGSI or ZEE is to be used. An LGSI is nearly identical to a ZEE, but for an LGSI each flange will have a different width, so that one flange will be roughly $\frac{1}{4}$ " wider than the other. This is so that the girts will interlock a bit easier. Thus, when installing LGSI wall girts, install them in such a manner that the first girt attached should have its wider flange (note that there may be a small triangle-shaped hole in the web of the LGSI, which points toward the wider flange) connected to the column. This will easily allow the next girt to be installed so that, if its narrower flange is connected, it will easily interlock with the other girt. When installing all wall girts, please keep this fact in mind.

Note that when installing wall girts, LGSIs or ZEEs can generally be installed with the outside flange of the girt pointing either up or down. Please refer to the engineering plans for any specific requirements.

Pro tip: When overlapping girts, per the engineering plans, only a 3" overlap of the girts is required, though the width of a single column is 4". Your girts should be ordered so that a 3" overlap is assumed at all single columns, and a 7" overlap is assumed at all double columns. When overlapping girts, a temporary tek screw or bolt can be installed at the inside edge of the first installed girt, within $\frac{1}{2}$ " of the edge of the column. When the second girt is installed later, the previously installed screw or bolt will not interfere with the second girt, allowing for easy installation. Once the second girt is in place, the screws or bolts required by engineering plans can be installed. This method is illustrated in Detail A and Detail B below.

In some cases, endwall girts will need to attach directly to the rafter. When this occurs, bend out the upper stiffener lip of the endwall girt, so that it lays flush against the edge of the endwall rafter. Please see the instructions and illustrations below and on the following page (specifically Detail D) as a reference on how to install girts which connect directly to the rafter.

When installing endwall girts to a corner column or to an endwall rafter (as shown in Details C and D below), make sure that the back of the endwall girt aligns with the back of the column or rafter. If the endwall girts are 6" or larger, this will mean the corner columns and endwall rafters will be set in from the edge of the slab. For more information,



please see the engineering plans, or see the “Set out the location of all columns and all anchor bolts” section of the main installation manual.

Please see the details on the engineering plans for more information on installing wall girts and please see illustrations on the next two pages as a reference for installing wall girts. Note that in the illustrations, not all components are shown for clarity. Double and single-columns are shown, but your building will not have both double and single interior sidewall columns. Instead it will be one or the other.

Note that though girts are graphically shown on the engineering plans, locations shown are not exact.

If you are installing base angle, install this first. If you are not installing base angle, you will need to install a bottom girt, which should be located as close to the slab as possible without touching the slab.

Locate the next girt with its web being the up the column the maximum girt spacing. Remember to that the girt flange connected to the column should be pointed upward. The subsequent girts should be located up the column from the initial girt at maximum girt spacing. Note that the final girt installed should be within the maximum girt spacing of the eave purlin. For the maximum girt spacing, please see the member and material schedule of the engineering plans. Note that there is both a sidewall girt spacing and an endwall girt spacing listed. Ensure that you use correct spacing for each wall.

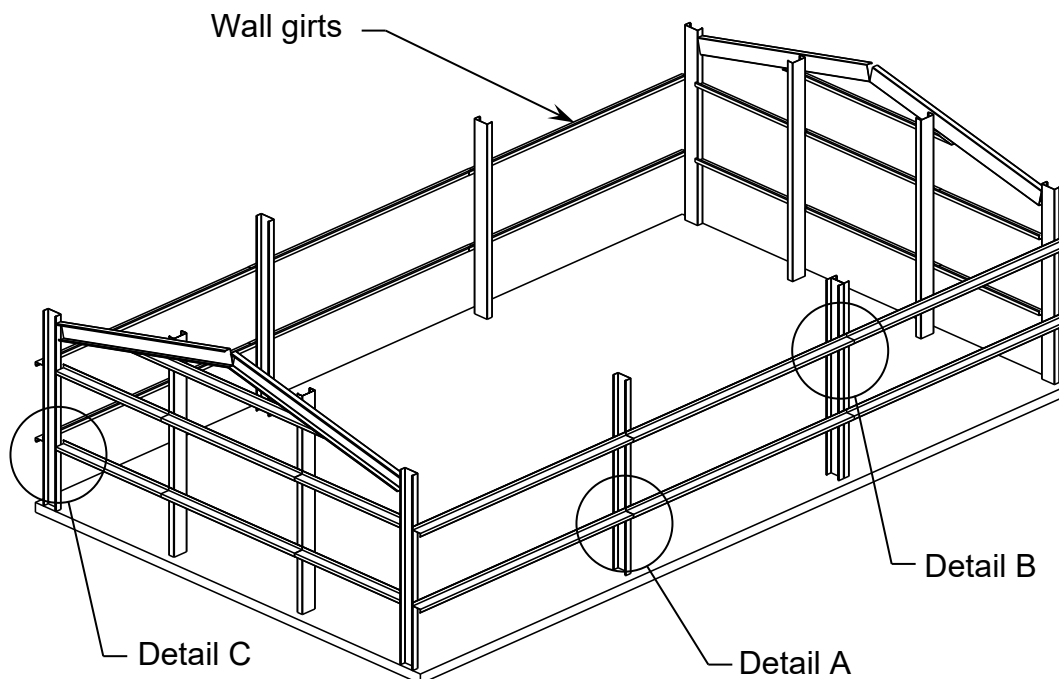



Detail A
Girt to single-column assembly

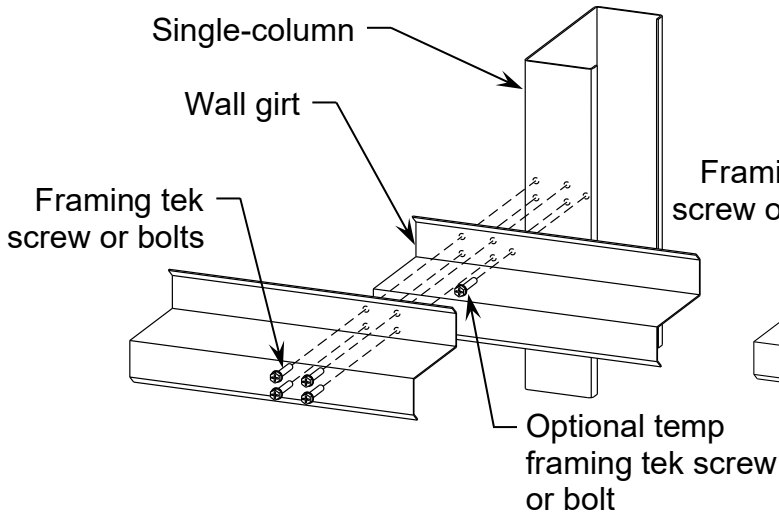

Detail B
Girt to double-column assembly

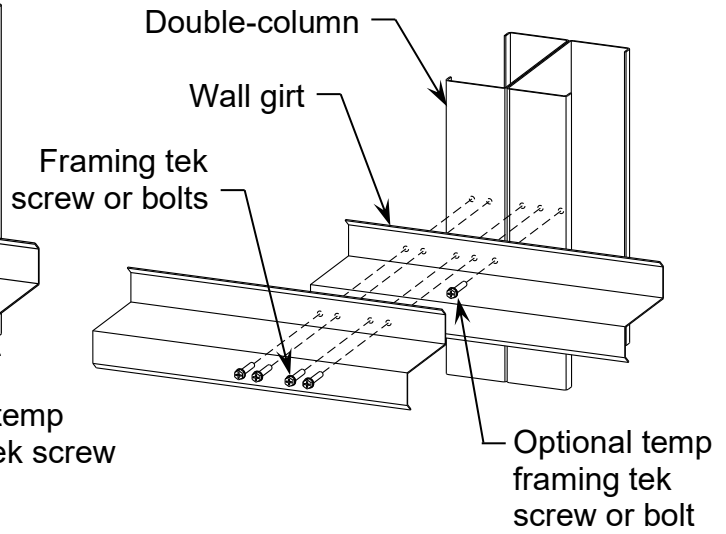

Detail C
Endwall girt to column assembly

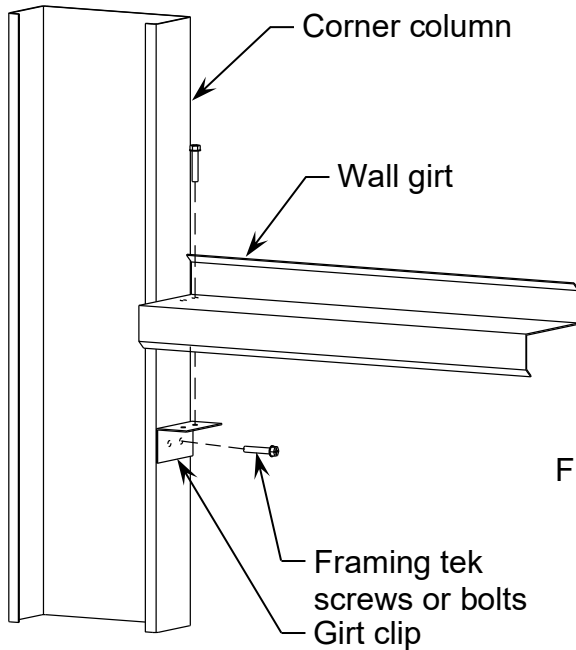

Detail D
Endwall girt to rafter assembly

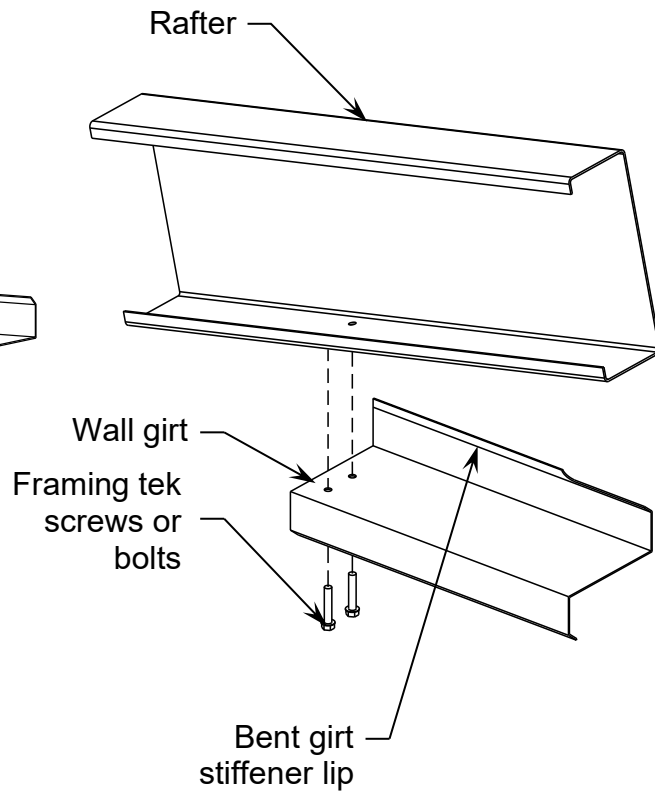



Girt and Purlin Flange Bracing Installation

After installing all wall girts and roof purlins, you may have to install girt and purlin flange bracing. This is specified on the engineering plans. Please see number and location on the sidewall elevations.

If necessary for your building, you will need to use the strapping provided and install this using pan head framing screws to attach to the wall girts, roof purlins and eave purlins and a concrete anchor to attach to the foundation. Please see the column base installation section for more information on installing these anchor bolts.

Please see the details on the engineering plans for information on strapping, screw and bolt types required as well as for specific installation instructions.

Please see the illustrations below and on the next page as a reference on how to install girt and purlin flange bracing.

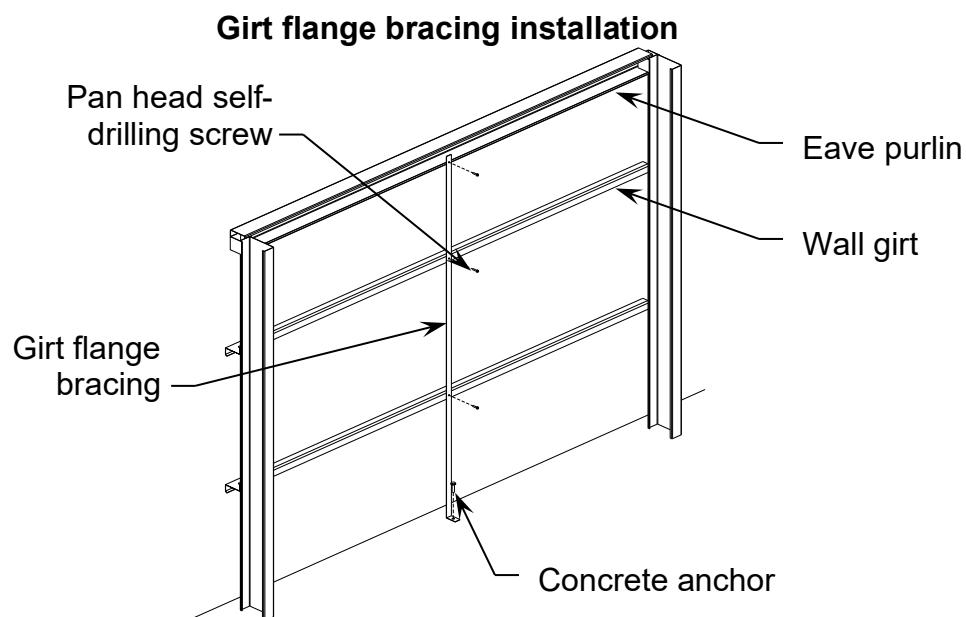



Purlin flange bracing installation

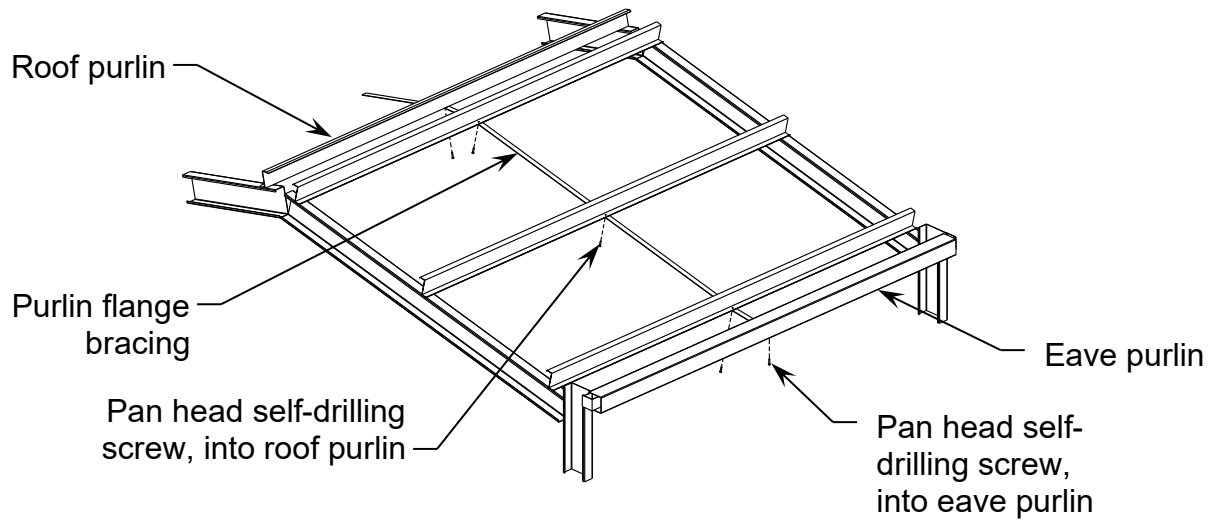



Haunch Bracket Installation

Connect columns to rafters using the haunch bracket with bolts. Please see the details on the engineering plans for number, type, and shape of haunch brackets and see the member and material schedule for number and type of columns and rafters. Please see the illustrations below as a reference for attaching the columns to the rafters using haunch brackets.

Note that in some cases, not all holes in the haunch bracket will have a bolt installed, but will instead remain empty. Please see the engineering plans for the exact placement and number of installed bolts.

Single-column to rafter assembly

Double-column to rafter assembly

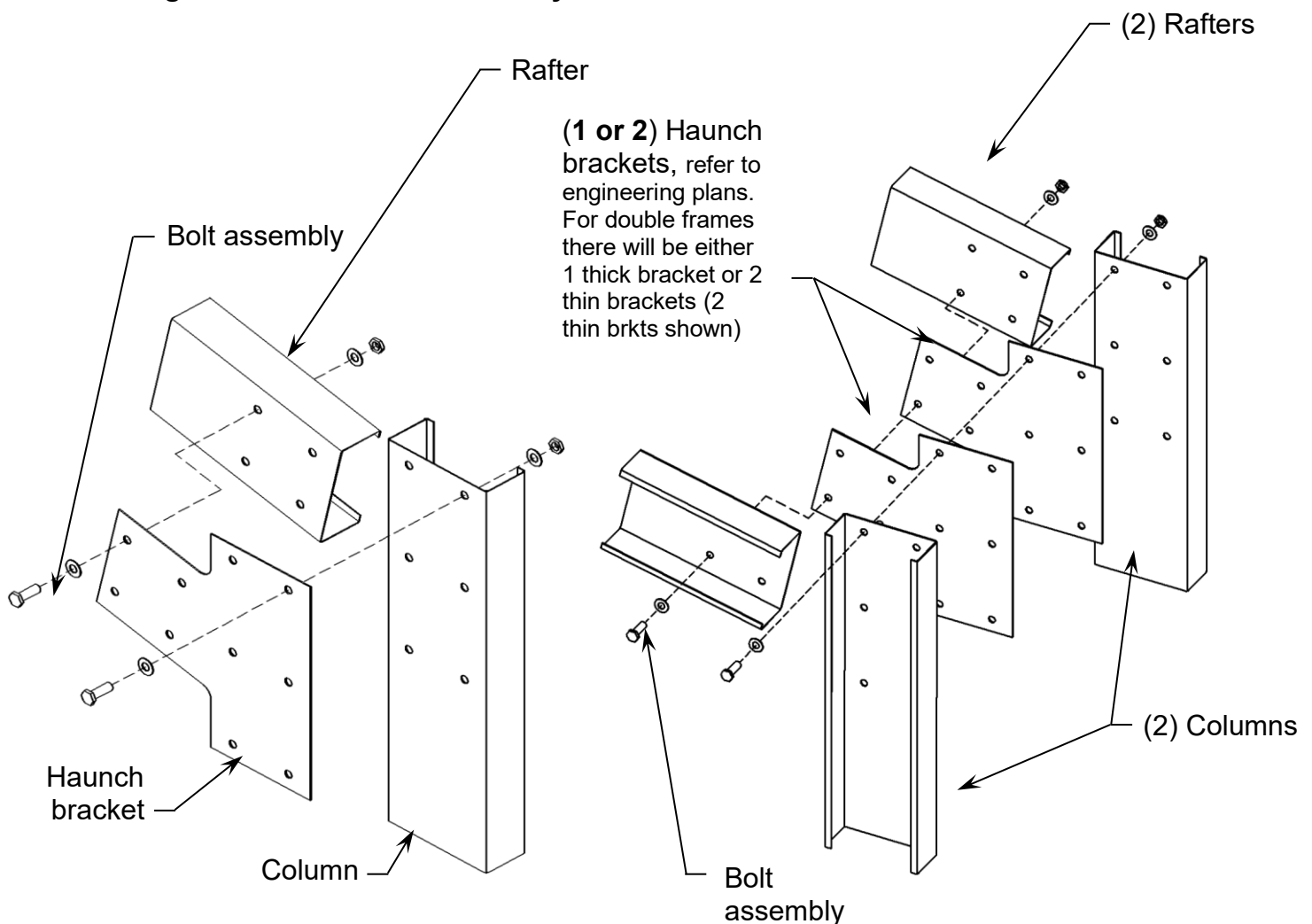



Knee Brace Installation

To install a knee brace you must first cope the flanges of the knee brace CEE section. In some building configurations, punches will be made on the flanges of the knee brace to indicate the sections to be coped. If your knee braces come with these punches, the flanges can be coped up to and including the punch. If punches are not present, you will have to calculate the exact locations to cope the flanges, using the information found on the engineering plans.

Once the CEE section is coped, you will attach it to the columns and rafters with bolts or screws, which are specified on the member and material schedule on the engineering plans.

If you are installing the haunch braces using framing bolts, holes will have either been factory punched or will need to be pre-drilled before installation, per engineering plans.

Refer to haunch connection detail on the engineering plans for the height of the bottom end of the knee brace relative to the foundation. Refer to the member and material schedule on the engineering plans for size, gauge and type of knee brace and number of bolts or screws necessary to install the knee brace.

Please see the illustrations below and on the following page as a reference for attaching the knee brace to the columns and rafters. Note that the exact location, number and type of the bolts or screws are specified on the engineering plans but are not represented on the illustrations below.

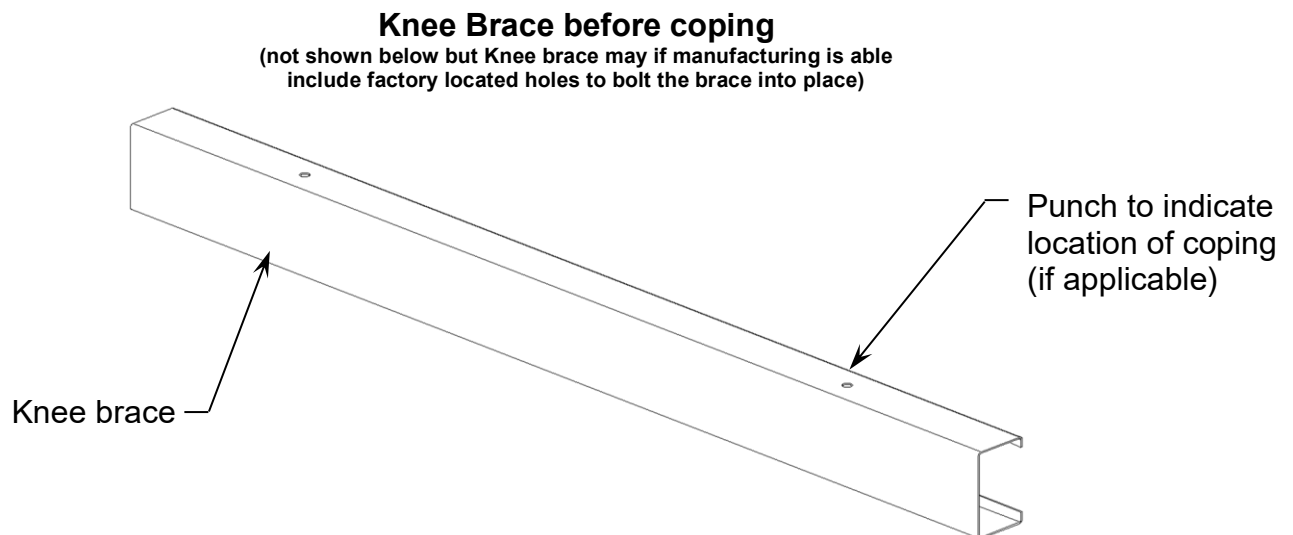



**Single-column
knee brace assembly**

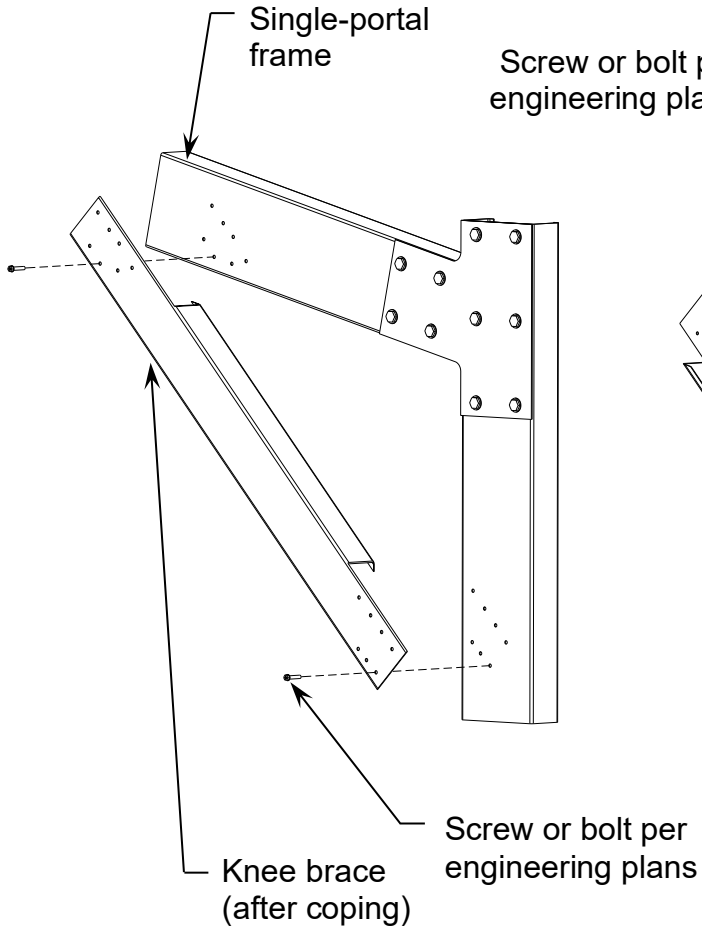

**Double-column
knee brace assembly**

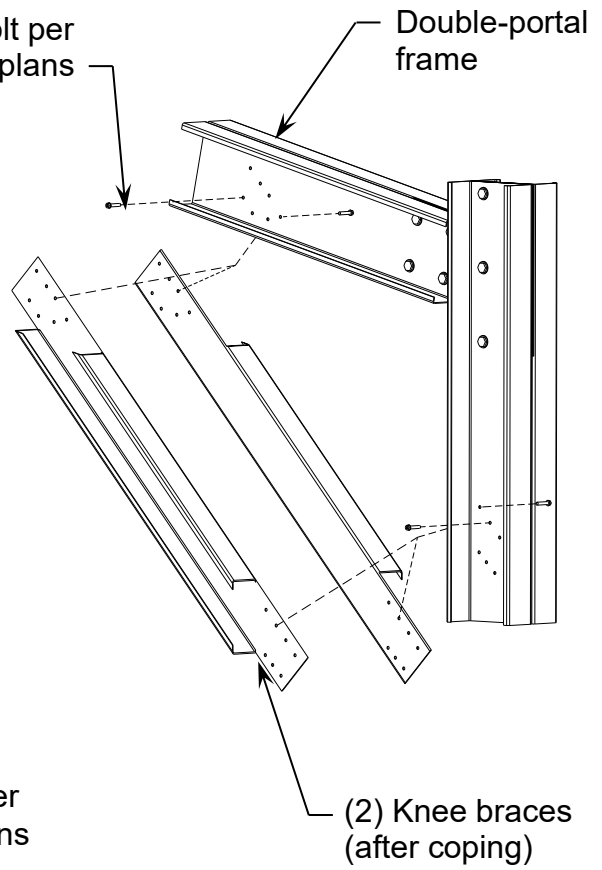



Leanto Rafter Installation

The leanto rafter is installed between the main building column and a leanto column. Installation can happen once the main building column is correctly installed, and after the leanto column is stood up and secured, with the haunch bracket properly installed at the top. In method 3 below, if applicable, wall sheeting must be installed as well.

Based on the configuration of your building, there are three possible installation methods. Typically, buildings with a leanto drop will use Method 1 described below, while buildings without a leanto drop will use Method 2. Buildings that have sheeting between the main building and leanto sections of the building can use method 3. Please refer to your engineering plans for the exactly method to be used on your building.

Method 1

In this method, the top of the leanto rafter is secured using an upside down haunch bracket attached to the main building column. Once the main building column is installed, attach the upside down haunch bracket to the column with the bolts as required by the engineering plans. Once secured, the leanto rafter can be installed between the main building column and the leanto column.

Leanto rafter to single-column assembly with drop

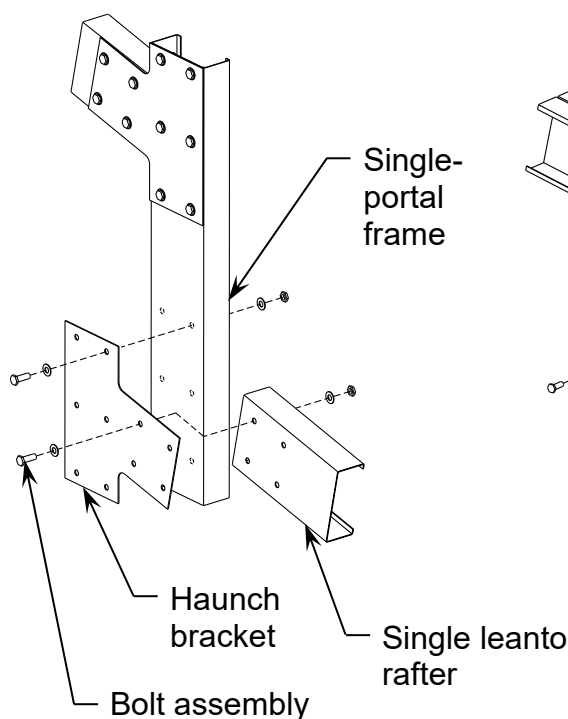

Leanto rafter to double-column assembly with drop

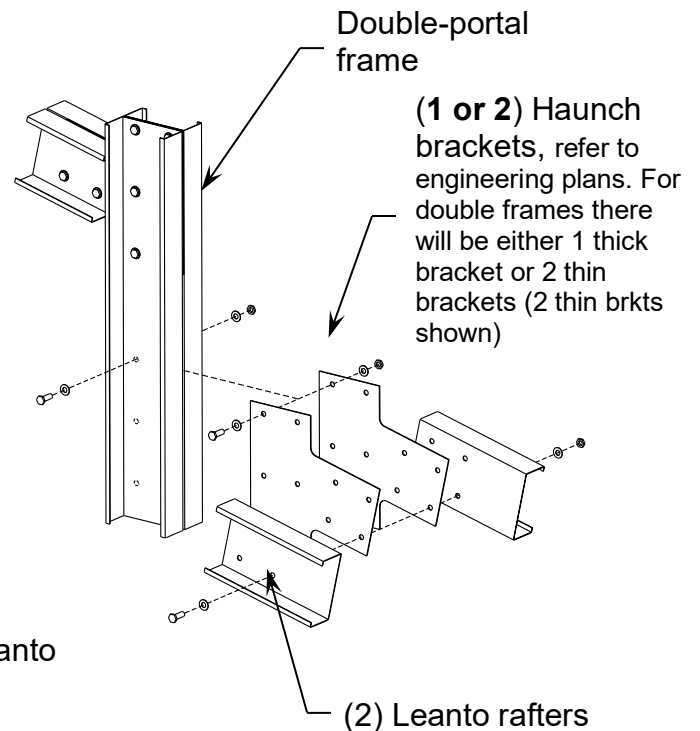



Method 2

In this method, the top of the leanto rafter is secured using a bent plate bracket. Once the main building column is secured, attach the bent plate bracket to the column at the correct height using the framing tek screws or bolts as indicated on the engineering plans.

Pro Tip: Since the bent plate bracket will typically come with a 90 degree bend, it will need to be bent more on site to match the leanto roof pitch. To easily bend the bracket to the required angle, install the leanto rafter to the bent plate while the bracket is still at 90 degrees, so that the rafter is perpendicular to the column.

When this is done, the unsecured end of the rafter will now be above the leanto column. At this point, carefully lower the unattached end of the rafter to the correct height so it can attach to the leanto column. This will allow gravity and the weight of the rafter to bend the bent plate bracket to the angle required.

Once in place, secure the leanto rafter to the leanto column as indicated on the engineering plans, typically using bolts for a standard haunch connection.

Leanto rafter to single-column assembly without drop

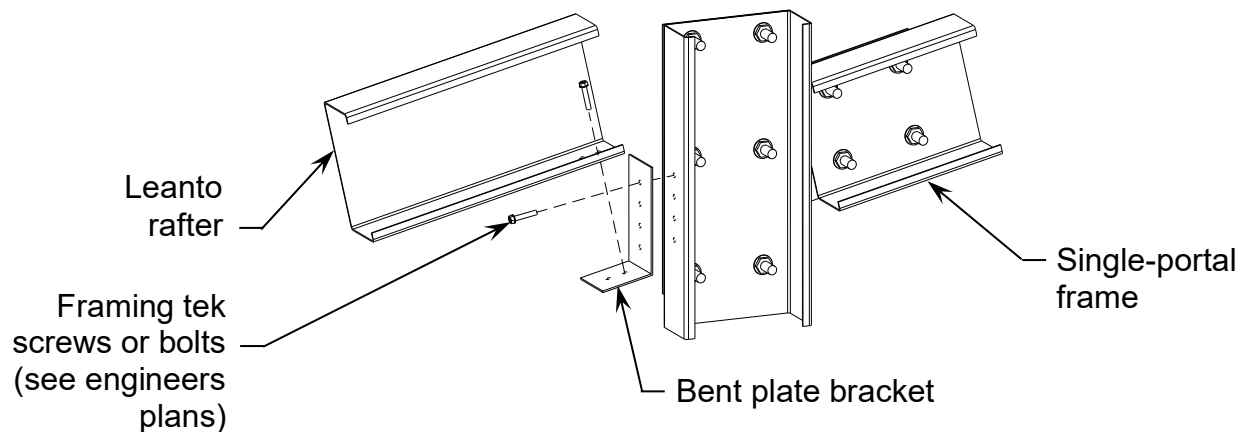

Leanto rafter to double-column assembly without drop

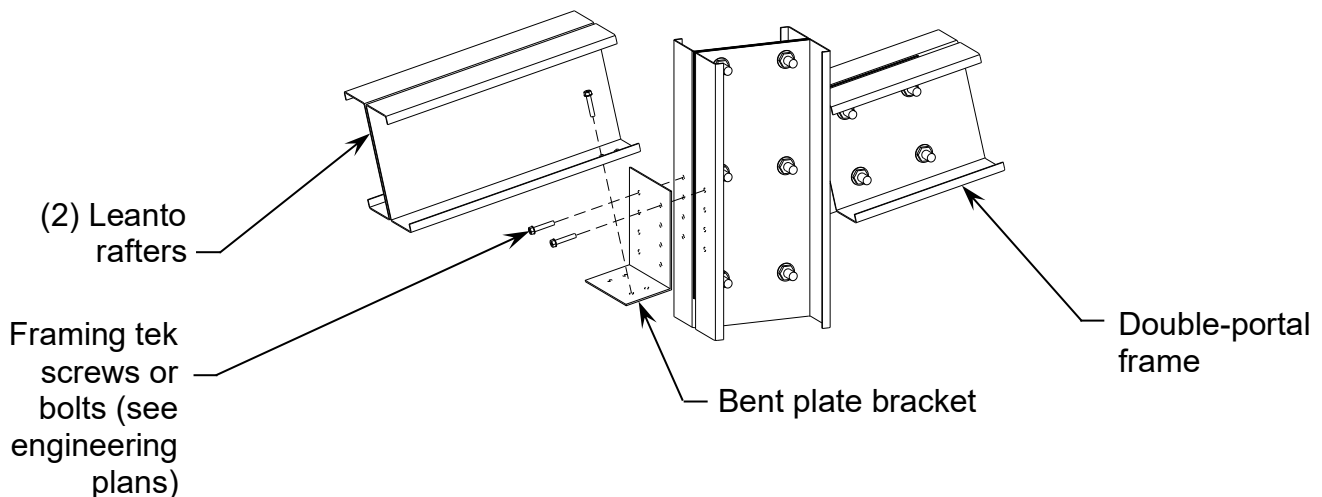

Method 3

If buildings where sheeting exists between the main building and the leanto, a leanto rafter connector can be constructed so that the leanto rafter will appear to be installed directly to the wall sheeting.

In this method, a CEE section is installed to the main building column using framing tek screws. Then, a Channel is placed over the CEE section and secured using framing tek screws or bolts. The channel should be secured so that the overall size of the CEE/Channel connector matches the girt size in the wall.

Once this connector is installed, the wall sheeting can be installed. The wall sheeting should be flush to the face of the connector. Once the sheeting is installed, the bent plate (as shown in method 2) will be installed to the connector, through the installed wall sheeting. Note that when installing the bent plate if it conflicts with the sheeting high-ribs then that part of the high rib will need removed to allow the bent plate to sit flat against the wall sheeting.

Leanto rafter installation with leanto rafter connector

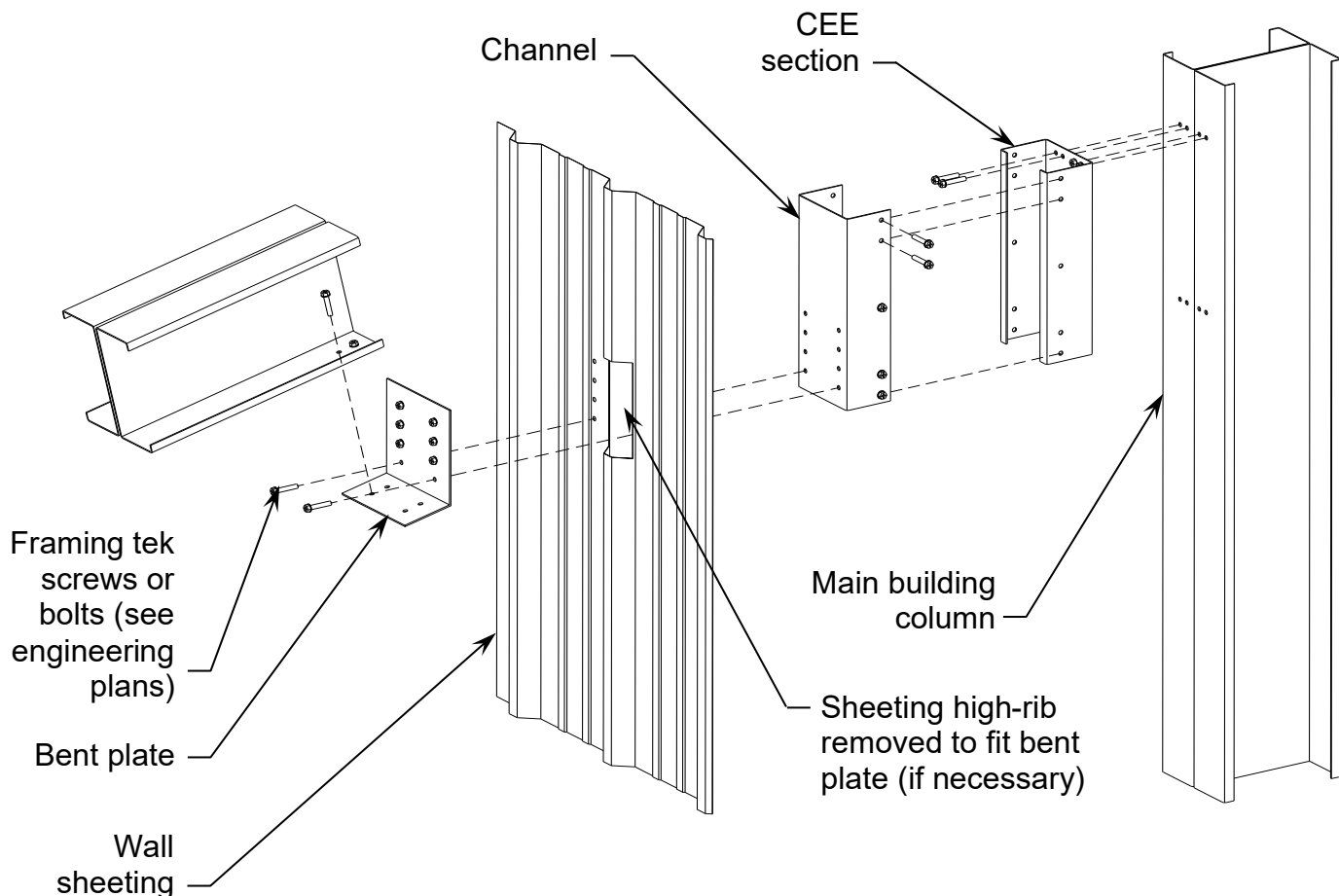



Mezzanine Installation

When beginning mezzanine installation, mezzanine floor brackets must be installed at the same time as the haunch brackets. If this is not done, it will impede the installation of the mezzanine and slow building installation. Please see engineering plans for location of single- and double-mezzanine girders, and for number of brackets to be installed.

After installing mezzanine floor brackets, install the mezzanine girders. These and the floor brackets will be installed using bolts. Please see engineering plans for location of single- and double-mezzanine girders. Note that when installing double-mezzanine girders, you must install extra bolts to fasten the two girders together. Please see the engineering plans for location of these bolts.

After installing the mezzanine girder, install any necessary mezzanine knee braces which are indicated on the engineering plans. For instructions on installation, please see the knee brace installation section above. Installation procedures for knee braces and mezzanine knee braces are nearly identical. The only difference for installing mezzanine knee braces will be that the top end of the brace will attach to the mezzanine girder as opposed to the rafter.

Next, install any necessary mezzanine posts. The location of these is indicated on the engineering plans. Note that most mezzanine post installation consist of double 4" CEEs are placed with their fronts together, and held together by framing tek screws and small sections of strapping. This front-to-front installation is shown on a following page. However, some larger CEEs are installed back-to-back similar to standard columns. Please see the engineering plans for exact requirements and placement of the mezzanine posts.

The installation of the top and bottom of the mezzanine posts can vary by post size and engineering requirements. Posts 6" or larger may require the standard column base installation described earlier in this appendix. 4" posts will use framing tek screws and concrete anchors. The top of the mezzanine post will be attached to the mezzanine girder above using framing tek screws and clips. Note that in some cases, strapping will also be required. Please see the engineering plans for specific information on installation requirements for mezzanine posts.

After that, install mezzanine floor joists. Note that these are installed in a similar fashion as the wall girts and roof purlins, interlocking and connecting to the mezzanine girders with framing tek screws or bolts. For information on installing these, please see the wall girt or roof purlin section. For information on joist size and location, please see engineering plans.

After installing the joists, a mezzanine edge joist will need to be installed. This CEE section is installed directly to the sidewall column with framing tek screws or bolts. Once all joists are installed, you will need to install the edge angle along the outside edges of the mezzanine joists. To do this, place angle on edge of joist, and install pan-head



screws or fin head bolts at each intersection of edge angle and joists. For exact angle and fastener requirements, see the engineering plans.

Also, you will need to stabilize the mezzanine joists, installing mezzanine joist stabilization strap in the center of all mezzanine girders not at the outer edges of the mezzanine joists. This strap will need to span at least two mezzanine joists, and will be installed using pan head screws or fin head bolts where the strap overlaps the mezzanine joists. For exact strap placement and requirements, as well as fastener requirements, please see the engineering plans.

If installing stairs in your building that would require an opening to be cut in your mezzanine, you will need to cut and reinforce the mezzanine joists. For more information on this, please see the engineering plans. Note that because of the custom engineering required for stairs, instructions for installation of stair opening and the stairs themselves are not provided in the manual. Please contact your building seller for information on installation of stairs.

Please see the illustrations below and on the following pages as a reference for installing a mezzanine in your building. For reasons of clarity, not all components are shown.

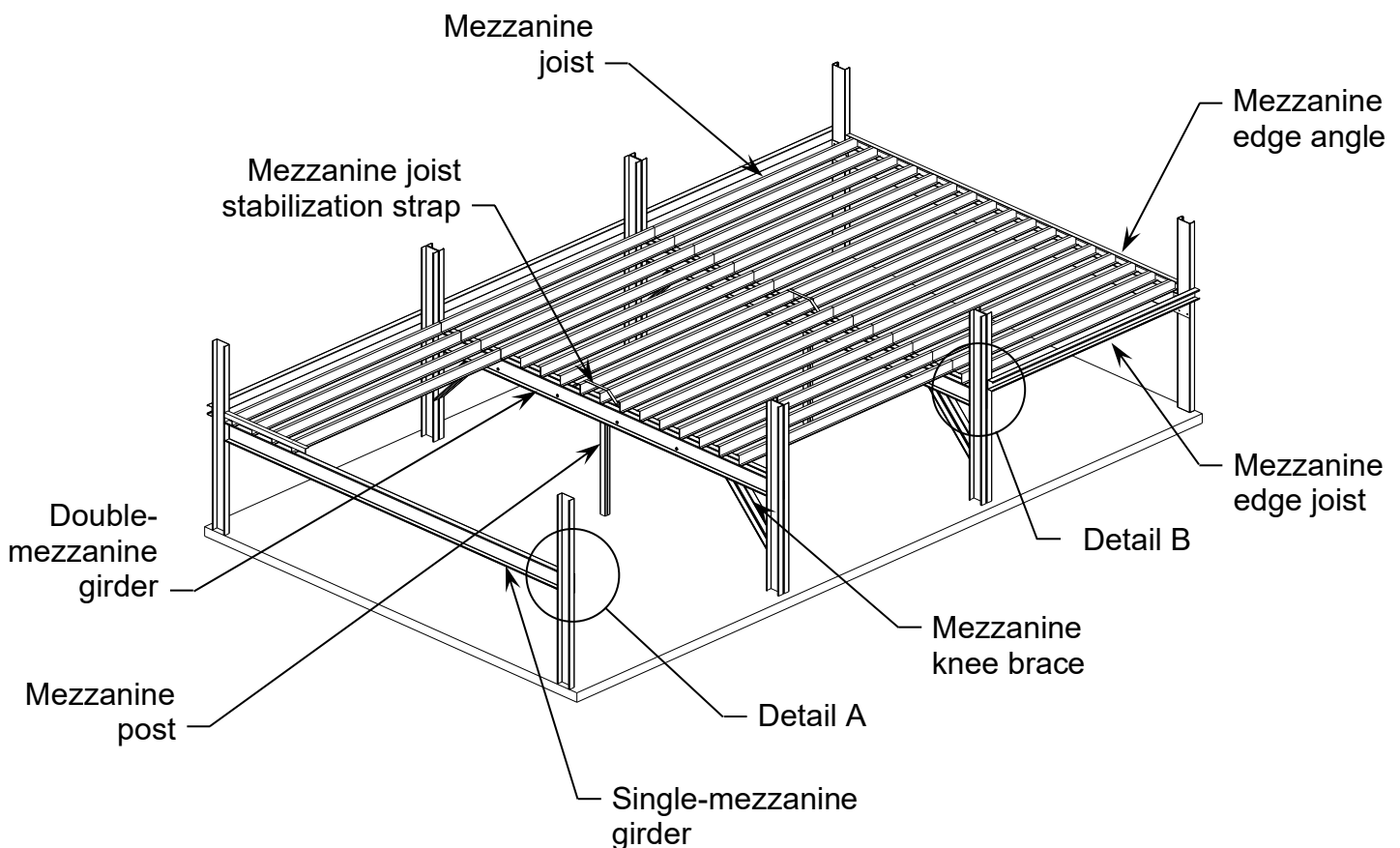



Detail A

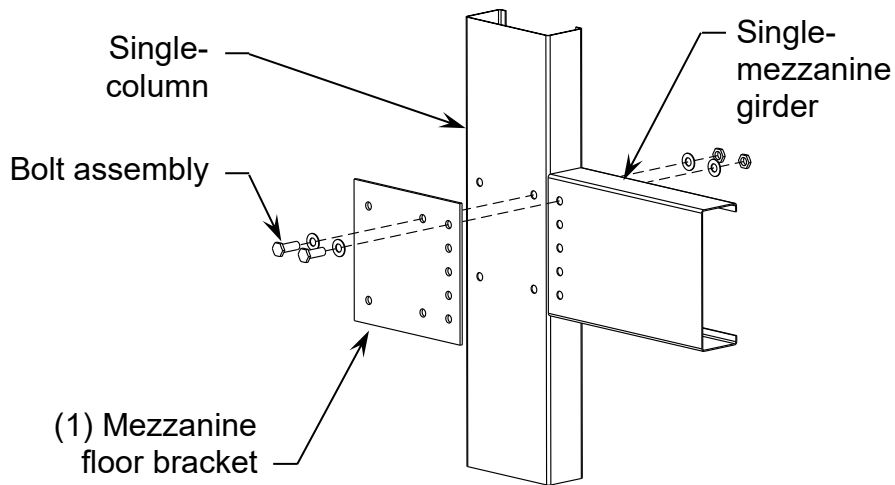

Detail B

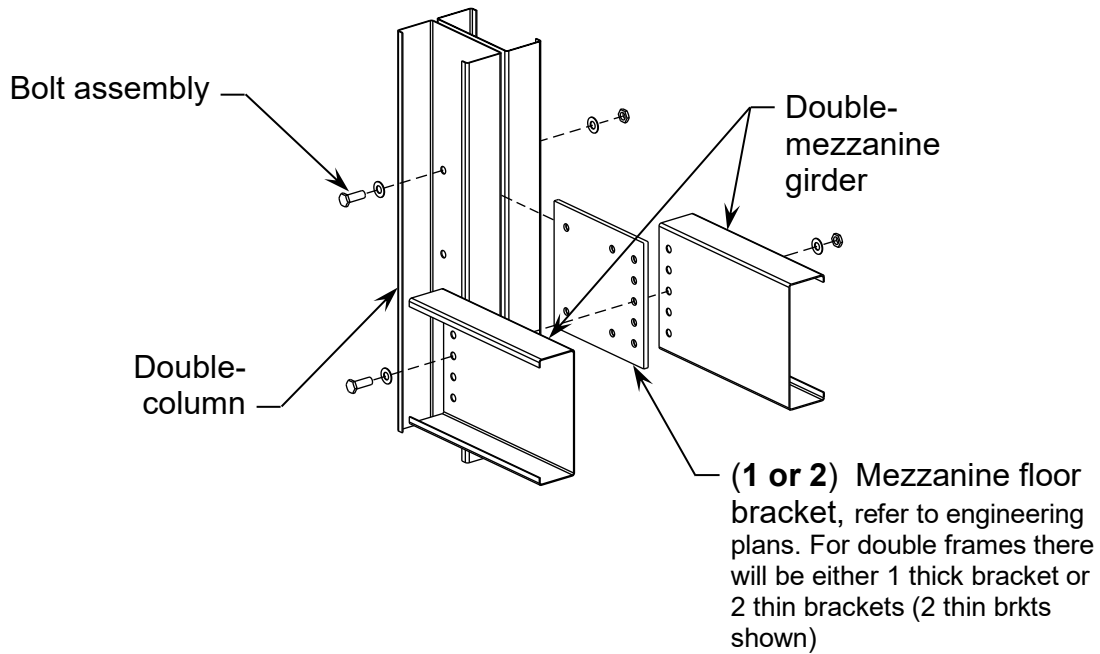



Front-To-Front Mezzanine Post Installation

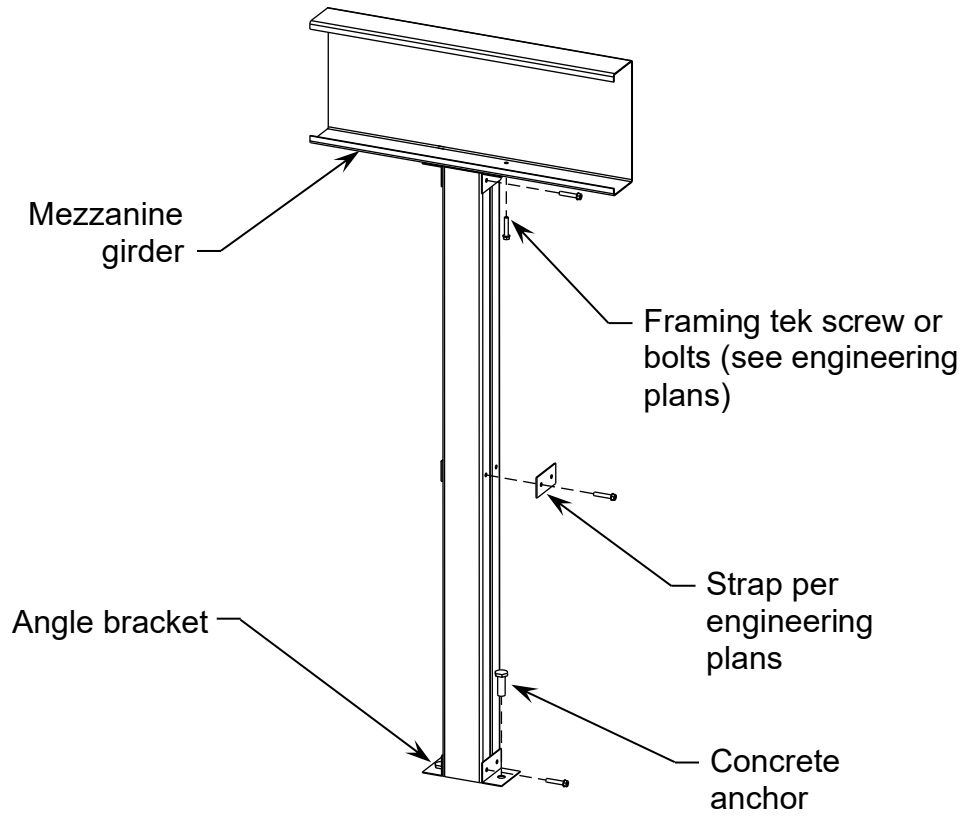

Mezzanine Stabilization Strap Installation

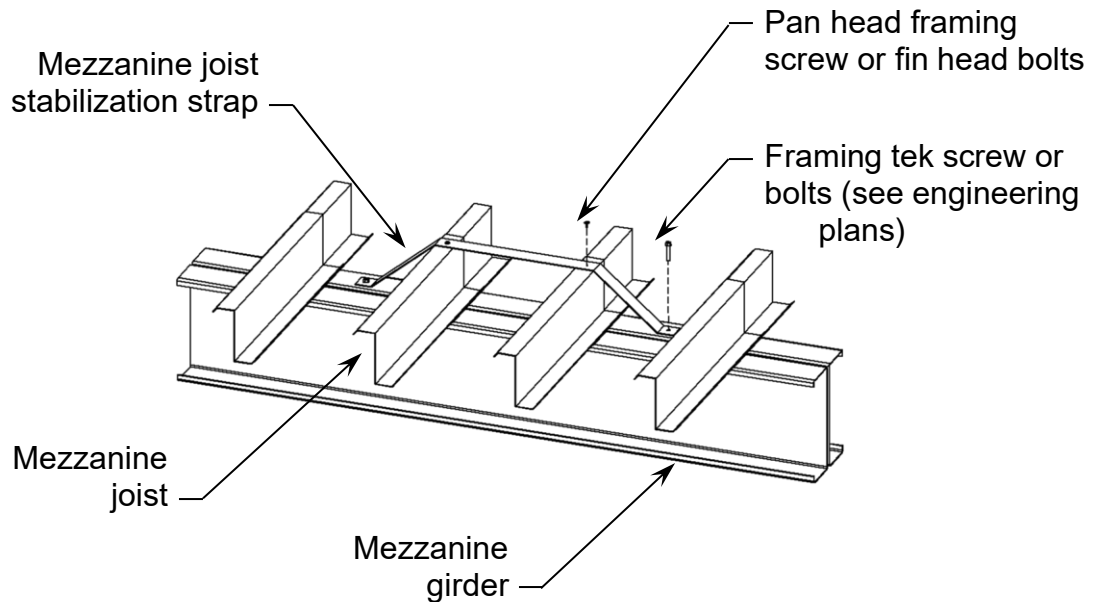



Mezzanine Edge Joist Installation

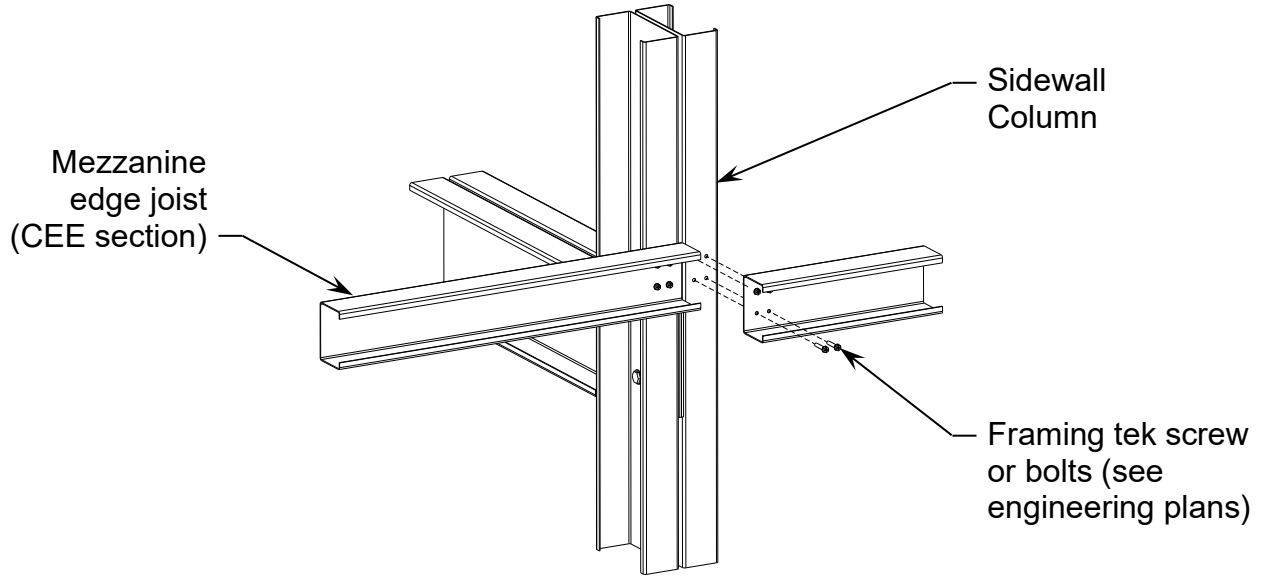

Mezzanine Edge Angle Installation

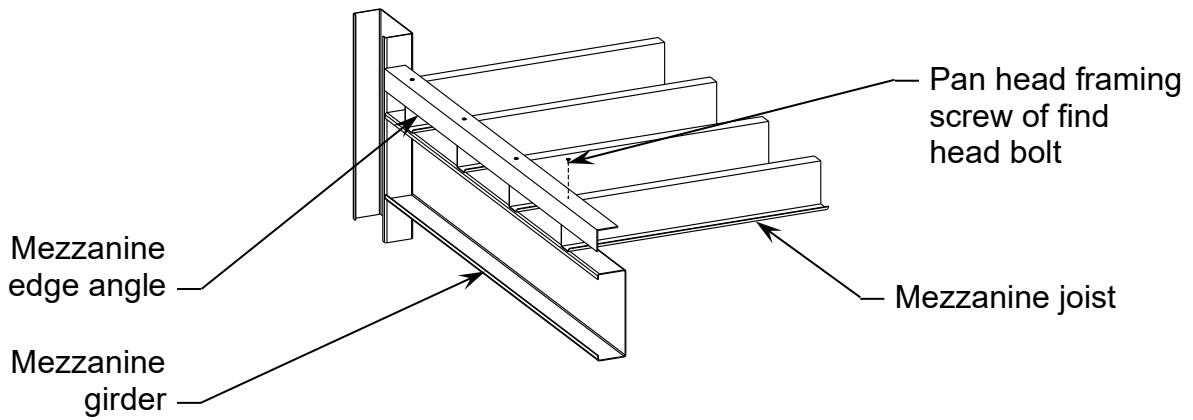



Moment Frame Installation

A moment frame is a connection of vertical and horizontal members that are installed to the front of sidewall columns when x-bracing cannot be installed.

In a typical installation, the vertical members of the moment frame will be installed to the front of the sidewall columns using screws or bolts. Once properly installed, the horizontal member will be installed to the top of the vertical members using bolts. Note that bolt holes may need to be drilled on-site. Please see the engineering plans for required location and number of bolts, as well as for screw requirements.

The illustration below shows the installation of a moment frame that spans a single bay at an interior sidewall bay. Please see engineering plans for any alternate installations that may be required when installed next to a corner column or if a moment frame spans multiple bays.

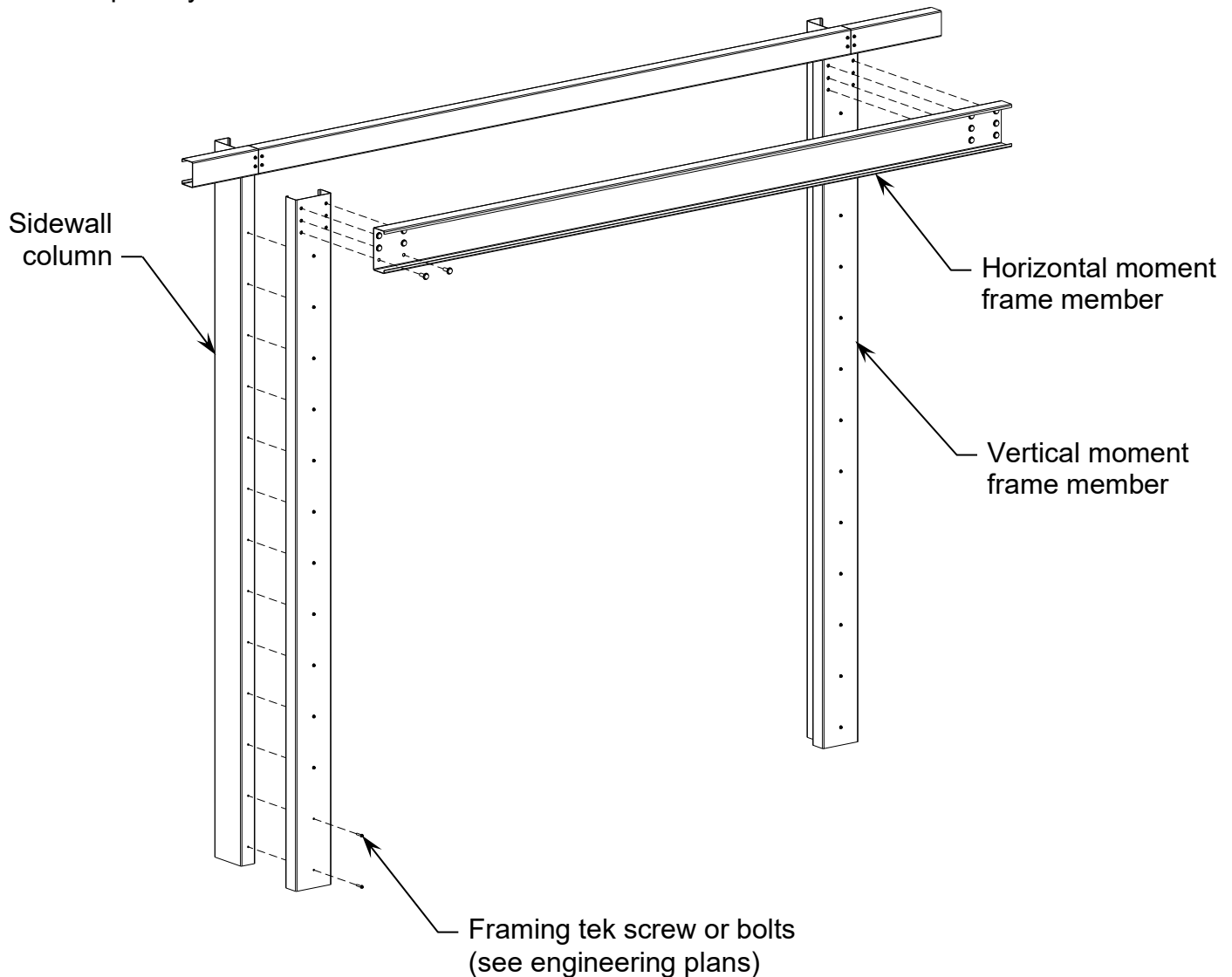



Open Bay Installation

If you have open bays in your building, those bays that are open will not typically contain any wall girts, with girts and sheeting from adjacent bays stopping at the edge of the columns for the open bay.

However, if your open bays have an open bay header, you will need to install open bay header girts to support your open bay header sheeting. If this is the case, an open bay header girt will be installed at the bottom edge of the open bay header, and, if the open bay header sheet is longer than the minimum required girt spacing for that specific wall, girts will need to be installed to support the open bay header sheet. Standard trim may be installed at the bottom and sides of the open bay header if necessary.

If an entire wall will consists of open bays, you will simply not install any of the wall girts for that entire wall unless directed otherwise on the engineering plans. Also note that if this is the case, you may be required to install moment frames. For location and installation instructions, please refer to the engineering plans.



Purlin Installation

Purlins are installed on the top of rafters of your building. Each purlin is connected from one rafter to the adjacent rafter using framing tek screws or bolts. When overlapping purlins, they *must* overlap at a rafter.

Note that for some buildings, LGSIs will be used to make up the purlins. Please check your engineering plans or order to see if an LGSI or ZEE is to be used. An LGSI is nearly identical to a ZEE, but for an LGSI each flange will have a different length, so that one flange will be roughly $\frac{1}{4}$ " wider than the other. This is so that the purlins will interlock a bit easier. Thus, when installing LGSI purlins, install them in such a manner that the first purlin attached should have its wider flange (note that there may be a small triangle-shaped hole in the web of the LGSI, which points toward the wider flange) connected to the column. This will easily allow the next purlin to be installed so that, if its narrower flange is connected, it will easily interlock with the other purlin. When installing all purlins, please keep this fact in mind.

Also, when installing interior and top purlins, make sure the flange that is connected to the rafter points downhill. The lowest purlin on gambrel style roofs should be installed the opposite direction to limit the length of unsupported sheeting.

Please see the details on the engineering plans for more information on installing purlins and please see illustrations below and on the following page as a reference for installing purlins. Note that in the illustrations, not all components are shown for clarity and that double and single-rafters are shown, but your building may not have both double and single-rafters. Instead it will be one or the other.

Pro tip: When overlapping purlins, per the engineering plans, only a 3" overlap of the purlins is required, though the width of a single rafter is 4". Your purlins should be ordered so that a 3" overlap is assumed at all single rafters, and a 7" overlap is assumed at all double rafters. When overlapping purlins, a temporary tek screw or bolt can be installed at the inside edge of the first installed purlin, within $\frac{1}{2}$ " of the edge of the rafter. When the second purlin is installed later, the previously installed screw will not interfere with the second purlin, allowing for easy installation. Once the second purlin is in place, screws or bolts as required by engineering plans can be installed. This method is illustrated in Detail A and Detail B below.

Note that though purlins are graphically shown on the engineering plans, locations shown are not exact. Locate the top purlin with its web being at the top end of the rafter (with the flange connected to the rafter pointed downhill). The subsequent purlins should be located downhill from the initial purlin at the maximum purlin spacing. Note that the final purlin installed should be within the maximum purlin spacing of the eave purlin. For the maximum purlin spacing, please see the member and material schedule of the engineering plans.

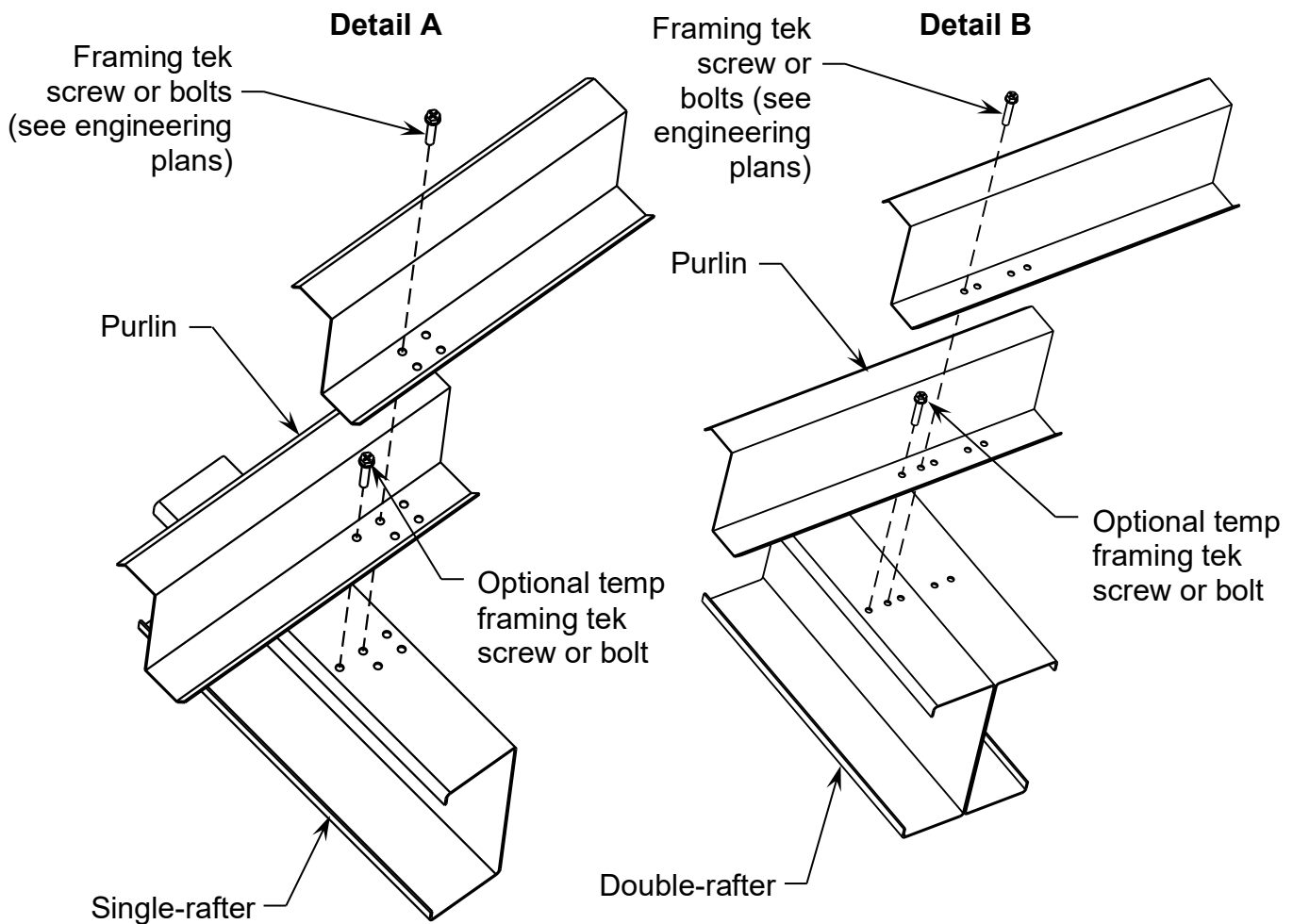
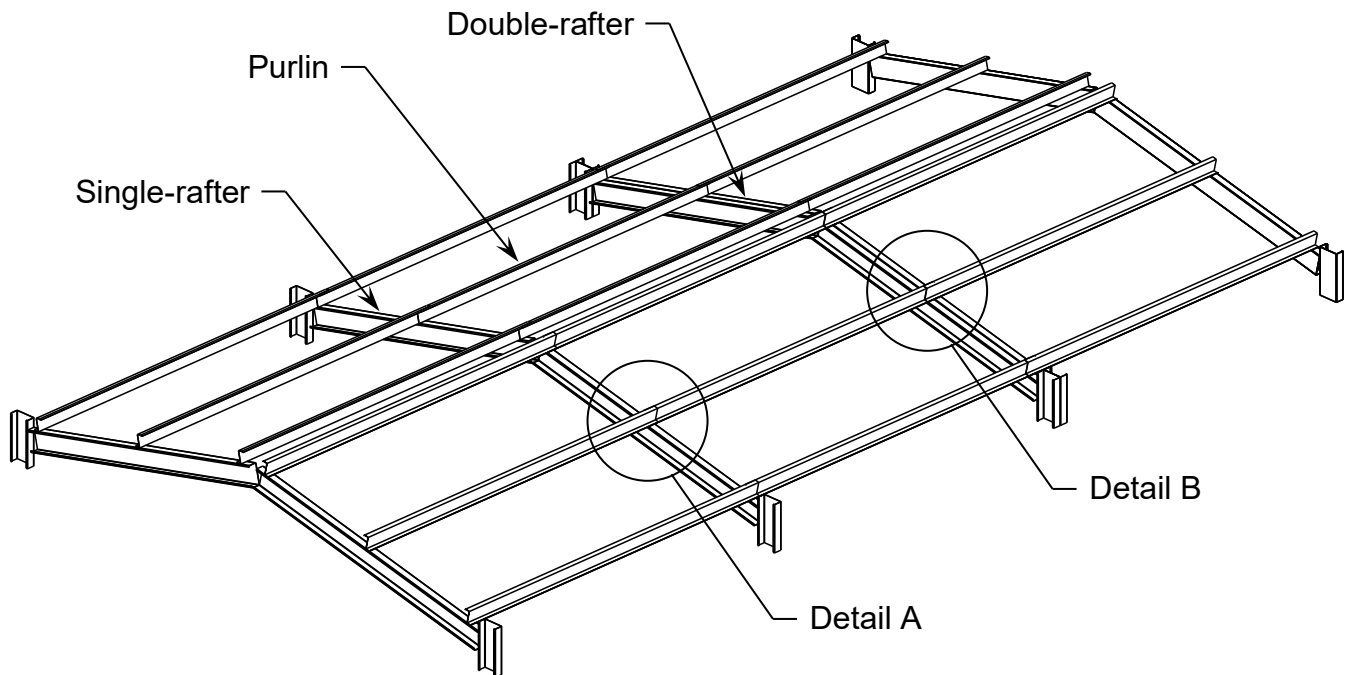



X-Bracing Installation

After installing wall girts and roof purlins, you will need to install x-bracing on the walls and on the roof, respectively. For exact location and layout of the x-bracing, please see the engineering plans, specifically the foundation plan and all elevations. Note that the specific strapping type is specified in the member and material schedule on the engineering plans. Further installation instructions and requirements specific for your building are found in the details section of the engineering plans.

Note that when installing x-bracing, strapping needs to be within 2" from the top and bottom of column or rafter, per the engineering plans.

Please see the illustrations below and on the following page as a reference on installation of x-bracing. Note that the illustrations do not show endwall x-bracing. However, installation is similar to the installation of x-bracing on the sidewall. Also note that double x-bracing is shown on the sidewall, while single x-bracing is shown on the roof. This is for reference only. Please refer to the member schedule on sheet 2 of your engineering plans for x-bracing requirements.

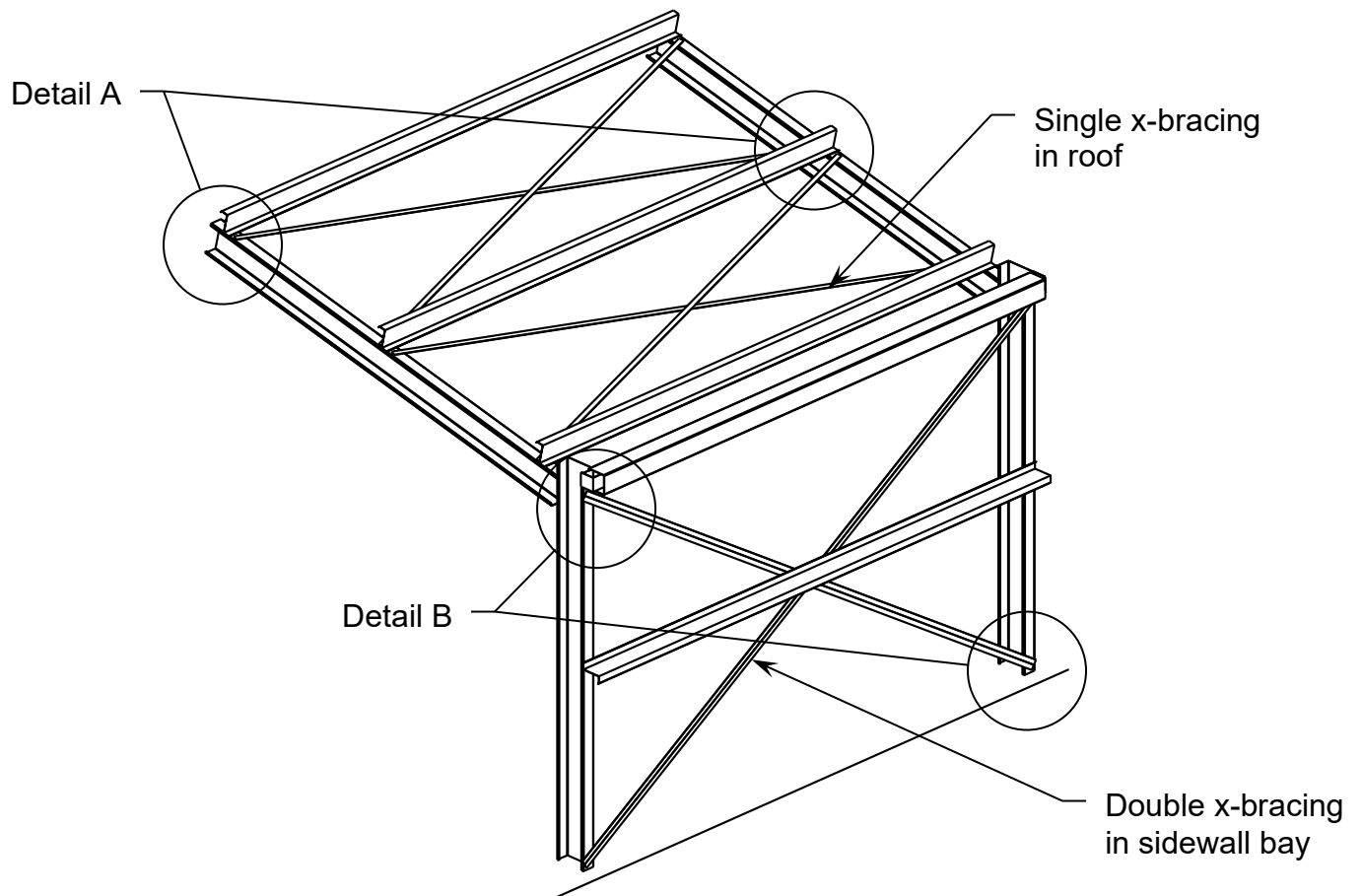

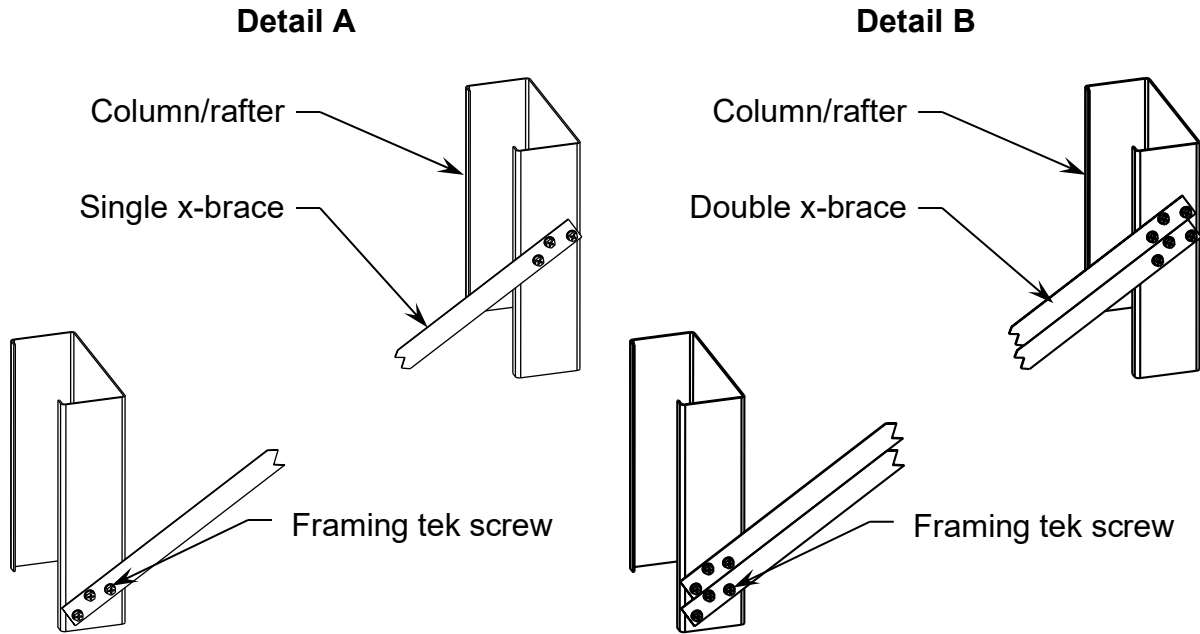

When installing x-brace, it is imperative that it be snug. However, you must not overtighten it. Overtightening will pull your columns out of plumb. Please keep this in mind while installing.

To get your x-bracing tight, first attach one end of the strap (in most cases the higher end) using a single screw, so the strap is attached to one column or rafter but is still able to pivot. Then pull the strap manually as tight as you can and clamp into place. Drill a hole through the strap ONLY using a framing tek screw. Do not drill into the column or rafter. Instead, using the hole you have just drilled, trace the hole on the column. Then, unclamp and reposition strap so you can drill a hole in the column. Drill this hole about 1/4" past where your previous mark was. Then, after both holes are drilled, angle a framing tek screw through both holes, as illustrated below. This process should tighten your x-brace, but not overtighten it. If it is not snug enough, or is overtightened and pulls columns or rafters out of plumb, remove and re-install the x-brace.

